

ROBO-8115VG2AR



**ROBO-8115VG2AR**

**PICMG 1.3 Single Host Board**

Version 1.1

# ROBO-8115VG2AR

## Revision History

R1.0	Preliminary
R1.1	Update BP & USB information

## Contents

1	Introduction .....	10
2	Specifications .....	11
2.1	Supported Operating Systems .....	12
2.2	Mechanical Dimensions .....	13
2.3	Power Consumption .....	15
2.4	Environmental Specifications .....	16
3	Hardware Configuration .....	18
3.1	Jumpers and Connectors .....	18
3.2	Jumpers Settings .....	20
3.3	Connector Settings .....	23
	J8/J15: USB2.0/3.0 connector(Pitch 2.0mm): .....	26
	J19/J20/J23/J24: COM1/COM2/COM3/COM4 Pin Header(Pitch 2.54mm).....	31
4	Signal Descriptions .....	37
4.1	Watch Dog Signal .....	37
4.2	GPIO Signal .....	41
5	System Resources .....	44
5.1	Intel® Comet lake-S PCH .....	44
5.2	Main Memory .....	44
5.3	Installing the Single Board Computer .....	45
5.3.1	Chipset Component Driver .....	45

# ROBO-8115VG2AR

5.3.2	Intel® HD Graphics 630 .....	46
5.3.3	Intel LAN I210AT/I219LM Gigabit Ethernet Controller.....	46
6	BIOS Setup Items .....	47
6.1	Introduction .....	47
6.2	BIOS Setup .....	47
6.2.1	Main.....	49
6.2.2	Configuration .....	52
6.2.3	Security .....	88
6.2.4	Boot .....	89
6.2.5	Save & Exit.....	91
7	Troubleshooting .....	93
7.1	Hardware Quick Installation .....	93
7.2	BIOS Setting.....	94
7.3	FAQ.....	95
8	Portwell Software Service .....	97
9	Industry Specifications .....	98
9.1	Industry Specifications.....	98

## Preface

This user's guide provides information about the components, features, connectors and BIOS Setup menus available on the ROBO-8115VG2AR. This document should be referred to when designing PICMG 1.3 application. The other reference documents that should be used include the following:

- ✧ Intel Comet Lake-S Design Guide
- ✧ Intel Comet Lake-S Specification

Please contact Portwell Sales Representative for above documents.

## Disclaimer

The information contained within this user's guide, including but not limited to any product specification, is subject to change without notice.

Portwell provides no warranty with regard to this user's guide or any other information contained herein and hereby expressly disclaims any implied warranties of merchantability or fitness for any particular purpose with regard to any of the foregoing. Portwell assumes no liability for any damages incurred directly or indirectly from any technical or typographical errors or omissions contained herein or for discrepancies between the product and the user's guide. In no event shall Portwell be liable for any incidental, consequential, special, or exemplary damages, whether based on tort, contract or otherwise, arising out of or in connection with this user's guide or any other information contained herein or the use thereof.

## Trademarks

Product names, logos, brands, and other trademarks featured or referred to within this User's guide or the Portwell website, are the property of their respective trademark holders. These trademark holders are not affiliated with Portwell, our products, or our website.

## Warranty

Portwell makes no representation, warranty or guaranty, express or implied regarding the products except its standard form of limited warranty (“Limited Warranty”). Portwell may in its sole discretion modify its Limited Warranty at any time and from time to time.

Beginning on the date of shipment to its direct customer and continuing for the published warranty period, Portwell represents that the products are new and warrants that each product failing to function properly under normal use, due to a defect in materials or workmanship or due to non conformance to the agreed upon specifications, will be repaired or exchanged, at Portwell’s option and expense.

## Certification

Portwell is certified to DIN EN ISO 9001:2000 standard.



## Technical Support

Portwell technicians and engineers are committed to providing the best possible technical support for our customers so that our products can be easily used and implemented.

We request that you first visit our website at <http://www.portwell.com.tw/support/> for the latest documentation, utilities and drivers, which have been made available to assist you. If you still require assistance after visiting our website then contact our technical support department by email at [tsd@mail.portwell.com.tw](mailto:tsd@mail.portwell.com.tw) for further assistance. Thank you!

## Notice

### SBC Handling and Installation Notice

#### ■ Handling and Installing SBC

**Caution:** *Do not just hold any single side of the SBC; hold evenly on both sides!*

- Heavy processor cooler may bend the SBC when SBC being held just on one side.
- The bending may cause soldering or components damaged.



# ROBO-8115VG2AR



## ■ Fix your SBC in System

**Caution:** Suggest your S.I or vendor to use a metal bracket to hold/fix the desktop or server grade SBC to avoid the vibration damage during transportation. Heavy processor cooler may bend the SBC when systems are during transportation without any holder.

Example:

- 4U chassis :
- Use L type metal or plastic or rubber bracket to hold SBC.

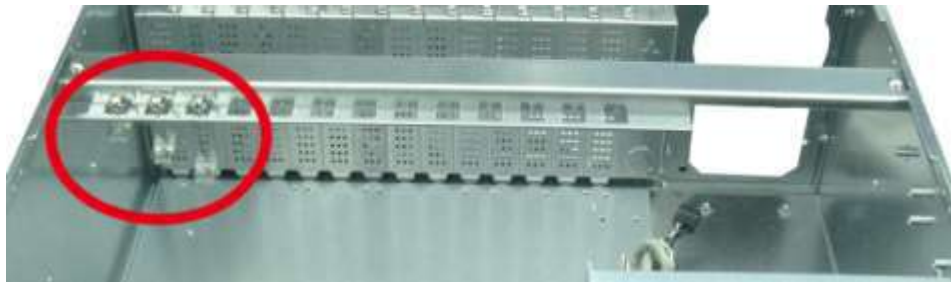



# ROBO-8115VG2AR

- 2U or 1U chassis: a metal bracket on the bottom of chassis to balance and support SBC from bending.

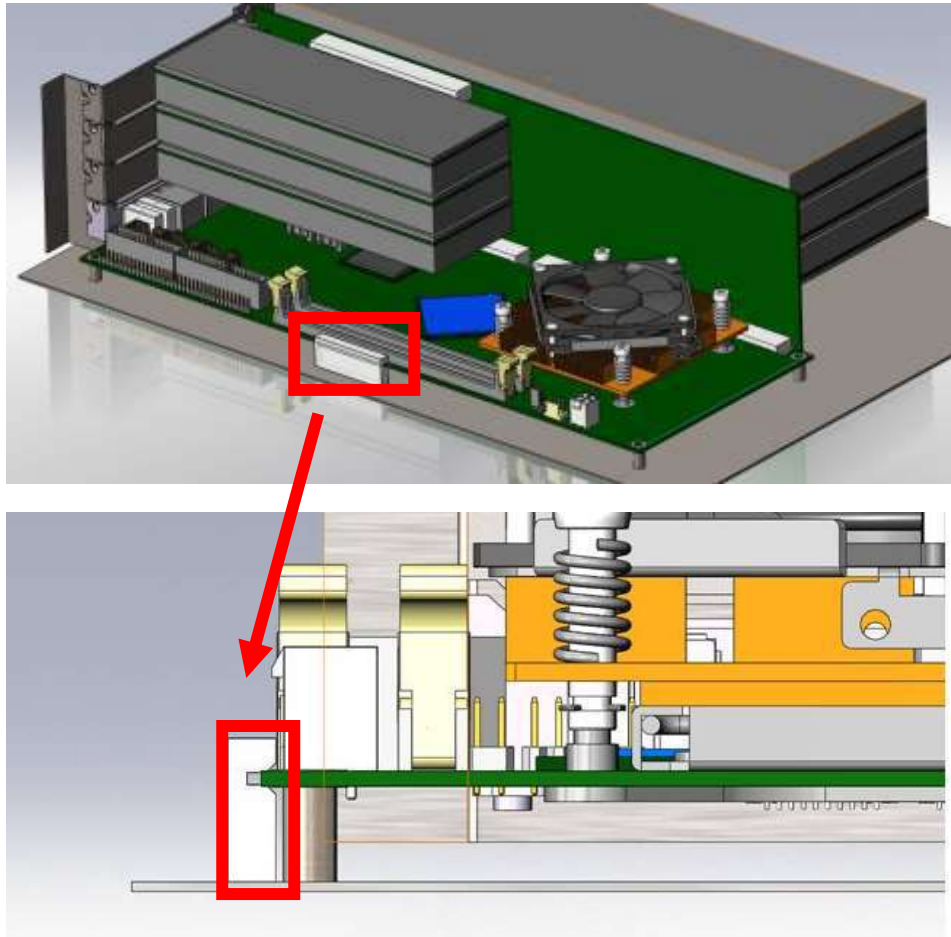

## 1 Introduction

ROBO-8115VG2AR, a PICMG 1.3 Single Host Board (SHB) with the latest Intel 10th Generation Core processors supported from W series Xeon processors to Core i3 processors. Portwell's ROBO-8115VG2AR implements flexible PCI Express Gen 3 expansion by one PCI Express x16 or two PCI Express x 8 or one PCI Express x8 and two PCI Express x4 with dedicated processor sku, which is ideal for a range of applications, such as Industrial Automation, Digital Signage, and Medical.

ROBO-8115VG2AR adopt Intel W480E and Q470E PCH. Providing up to 128GB DDR4 2666 Long-DIMM system memory supported with ECC or non-ECC option. ROBO-8115VG2AR with the 10th generation Intel® processor family features and integrated, enhanced graphics engine which provides significant 3D performance, up to DirectX® 12. It supports triple display function via DVI-I (VGA and DVI-D) and HDMI up to 4Kx2K. Rich I/O functions are also provided by ROBO-8115VG2AR single host board, which is 6x USB 3.2(Gen2), 8x USB 2.0 (4 ports via backplane), 5x SATA III ports (dual ports via backplane), 2x RS232 ports, 2x smart COM ports which select RS232/422/485 mode by bios adjustment, and dual Intel GbE LAN ports. It also supports on board TPM 2.0 to secure your applications.

For the industries who already have large install based systems, ROBO-8115VG2AR not only provides a way to upgrade to use the latest Intel processors, but also supporting legacy elements such as VGA, four PCI expansion, four Serial ports and PS/2 Keyboard and Mouse.

## 2 Specifications

<b>Main Processor</b>	◆ Intel® Comet Lake-S W series and Core™ i Processors
<b>System BIOS</b>	◆ AMI UEFI BIOS
<b>Main Memory</b>	◆ Up to 128 GB ECC or non-ECC DDR4 on four Long-DIMM sockets. Supports dual channel DDR4 2666 MHz SDRAM
<b>Graphics</b>	<ul style="list-style-type: none"> <li>◆ Controller: Intel® Gfx Gen 9, HD graphics 630</li> <li>◆ VGA: Resolution up to 1920 x 1200 @ 60Hz</li> <li>◆ DVI-D: Resolution up to 1920 x 1200 @ 60Hz (VGA+DVI-D on bracket by DVI-I port)</li> <li>◆ HDMI: Resolution up to 4096 x 2160 @ 24Hz</li> </ul>
<b>Expansion Interface</b>	<ul style="list-style-type: none"> <li>◆ From CPU: 1x PCI Express x16 or 2x PCI Express x8 or 1x PCI Express x8 + 2x PCI Express x4 by jumper setting (Gen3 up to 8.0 GT/s)</li> <li>◆ From PCH: 1x PCI Express x4 or 4x PCI Express x1 by different bios support (Gen 3 up to 8.0 GT/s)</li> </ul>
<b>SATA Interface</b>	◆ Five SATA III ports (SATA 6Gb/s), dual ports via backplane
<b>Input/Output</b>	<ul style="list-style-type: none"> <li>◆ Serial Ports: 2x RS-232 &amp; 2x RS-232/422/485 selectable by bios</li> <li>◆ USB Port: 2x USB 3.2(Gen2) on bracket, 4x USB 3.2(Gen1) on board header , 4x USB2.0 on board header and 4x USB2.0 via BP</li> <li>◆ GPIO connector: 8GPI + 8GPO</li> <li>◆ Audio Interface: Mic-In / Line-Out / Line-in (on-board header)</li> </ul>
<b>Ethernet</b>	<ul style="list-style-type: none"> <li>◆ Supports dual 10/100/1000 Mbps Ethernet port (s) via PCI Express x1 interface by Intel WGI219LM and WGI210AT controller</li> <li>◆ Dual RJ45 connector on bracket</li> </ul>
<b>TPM</b>	◆ On-board TPM 2.0 support (TPM IC: Infineon SLB9665TT2.0)
<b>High Drive GPIO</b>	◆ One pin-header for GPIO (8bit in & 8bit out)

<b>Mechanical and environmental specifications</b>	<ul style="list-style-type: none"><li>◆ Operating temperature: 0 ~ 60° C</li><li>◆ Storage temperature:-20 ~ 80° C</li><li>◆ Humidity: 5 ~ 90% non-condensing</li><li>◆ Power supply voltage: ATX</li><li>◆ Board size: 338.5mm x 126.39mm, 13.33" (L) x 4.98" (W)</li></ul>
--	--

## 2.1 Supported Operating Systems

The ROBO-8115VG2AR supports the following operating systems.

- ✧ Windows\* 10 IOT Enterprise RS51(64-bit)
- ✧ Ubuntu, SuSe, Redhat Enterprise 1,2 (Kernel 4.14)
- ✧ Yocto Project\* BSP tool-based embedded Linux distribution1 (64-bit)
- ✧ Wind River VxWorks 7.0

# ROBO-8115VG2AR

## 2.2 Mechanical Dimensions

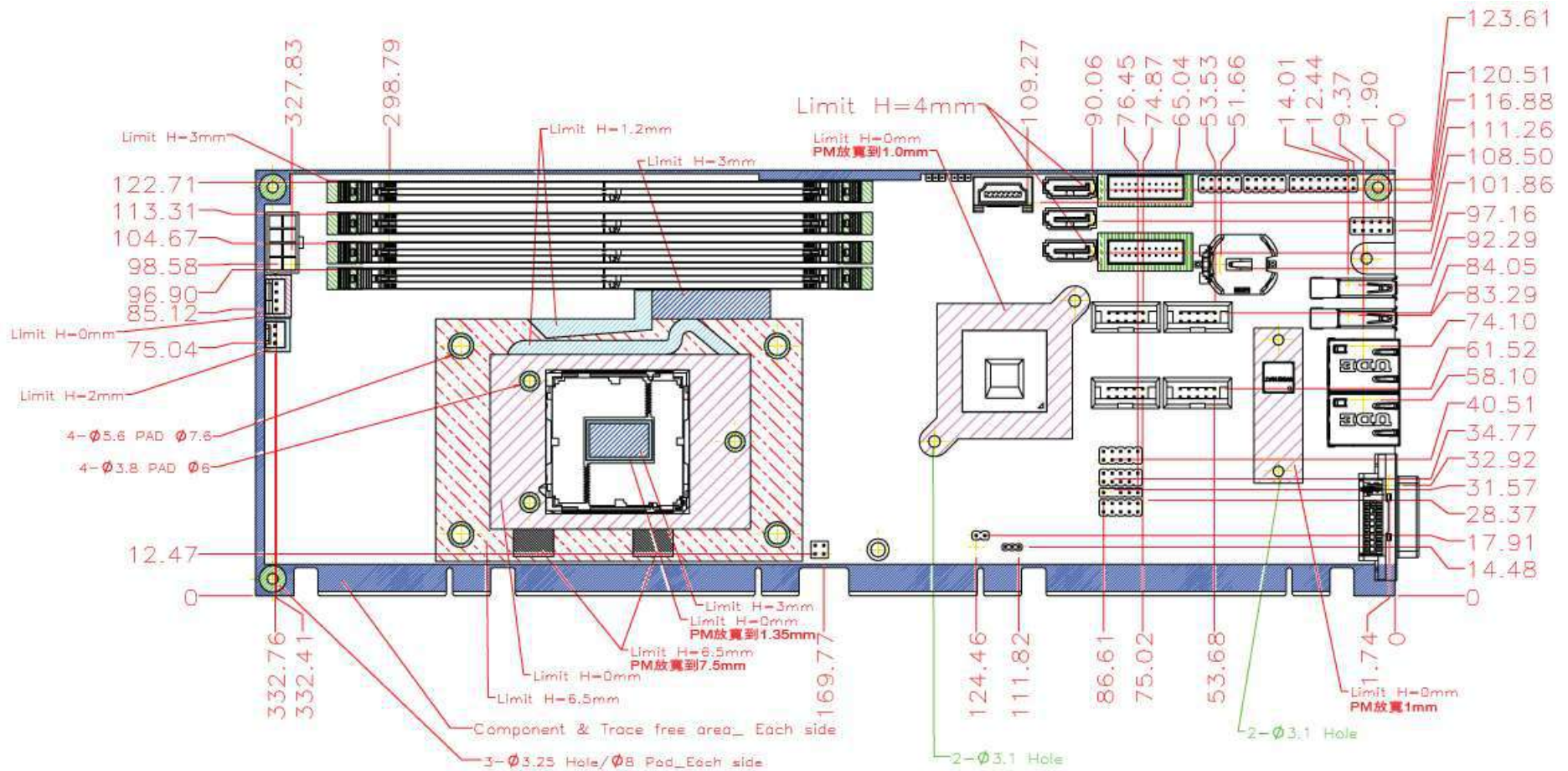

# ROBO-8115VG2AR

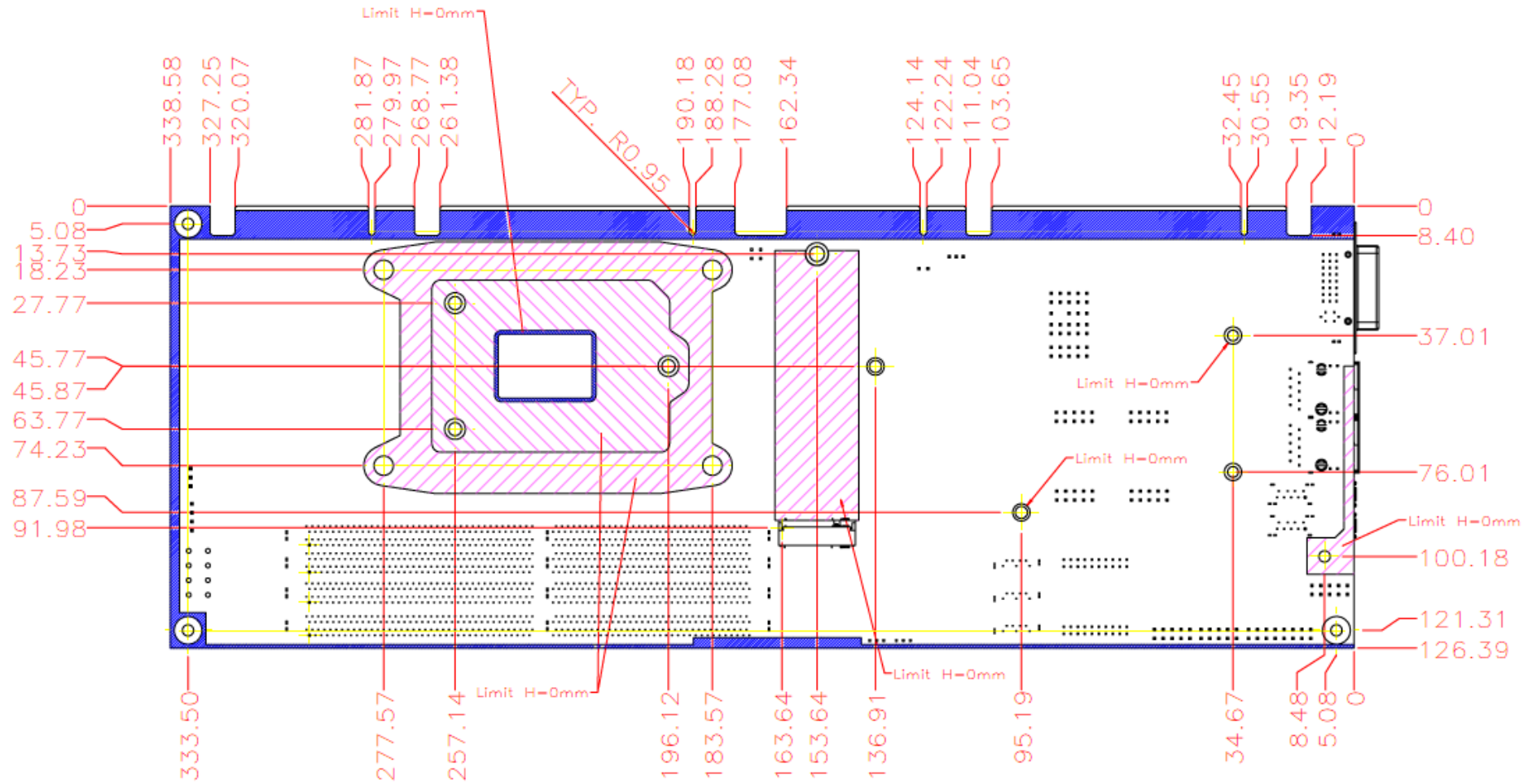

## 2.3 Power Consumption

Test Configuration	
CPU Type	Intel(R) Xeon(R) W-1270E CPU@3.4GHz
SBC BIOS	Portwell,Inc.R0B0-8115VG2AR BIOS Rev.:0.0.1(11192020)
Memory	SAMSUNG DDR4 2666V/32GB*2
VGA Card	Onboard , Intel(R) UHD Graphics P630
VGA Driver	Intel(R) UHD Graphics P630 , Verson:27.20.100.8336
LAN Card #1	Intel(R) Ethernet Connection(11)I219-LM
LAN Driver #1	Intel(R) Ethernet Connection(11)I219-LM , Version:12.18.9.20
LAN Card #2	Intel(R) I210 Gigabit Network Connection
LAN Driver #2	Intel(R) I210 Gigabit Network Connection , Version:12.18.9.6
Audio Card	Realtek High Definition Audio
Audio Driver	Realtek High Definition Audio , Version:6.0.1.6039
Chip Driver	Intel(R) Chipset Device Software , Version:10.0.19041.1
USB 2.0 Driver	USB Composite Device , Version:10.0.19041.1
USB 3.0 Driver	Intel(R)USB 3.1 eXtensible Host Controller-1.10(Microsoft) , Version:10.0.19041.423
EC Version	0.1(11/02/2020)
Hard Drive	WDC WD1004FBYZ-01YCBB2
Power Supply	GPS-500BBC REV:03F
Carrier Board	PBPE-12P4
Boot Mode Select	UEFI MODE

Power consumption			
<b>ATX:</b>			
Item	Power ON	Full Loading 10Min	Full Loading 30Min
CPU +12V	2.87 A	8.16 A	8.21 A
System +12V	0.47 A	1.26 A	1.25 A
System +3.3V	1.29 A	2.16 A	2.17 A
System +5V	2.20 A	3.78 A	3.92 A
System+ Device +12V	2.07 A	1.49 A	1.51 A
System+ Device +5V	1.70 A	2.27 A	2.42 A
CPU +Device +12V	3.15 A	8.12 A	8.14 A

## 2.4 Environmental Specifications

Storage Temperature : -20~80°C

Operation Temperature : 0~60°C

Storage Humidity : 5~90%

Operation Humidity: 10~90%



# ROBO-8115VG2AR

## Block Diagram

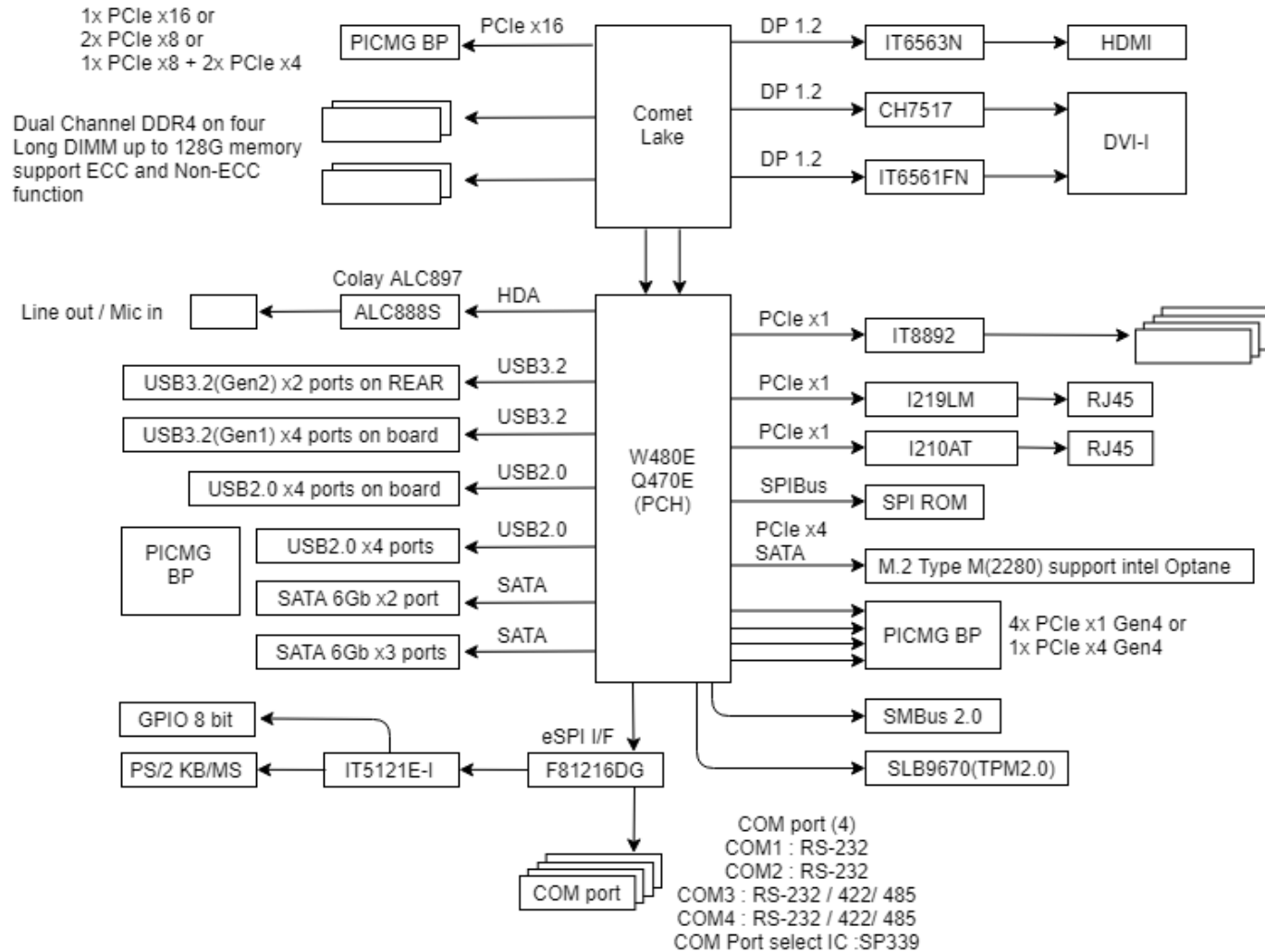

### 3 Hardware Configuration

#### 3.1 Jumpers and Connectors

This chapter indicates jumpers', headers' and connectors' locations. Users may find useful information related to hardware settings in this chapter.

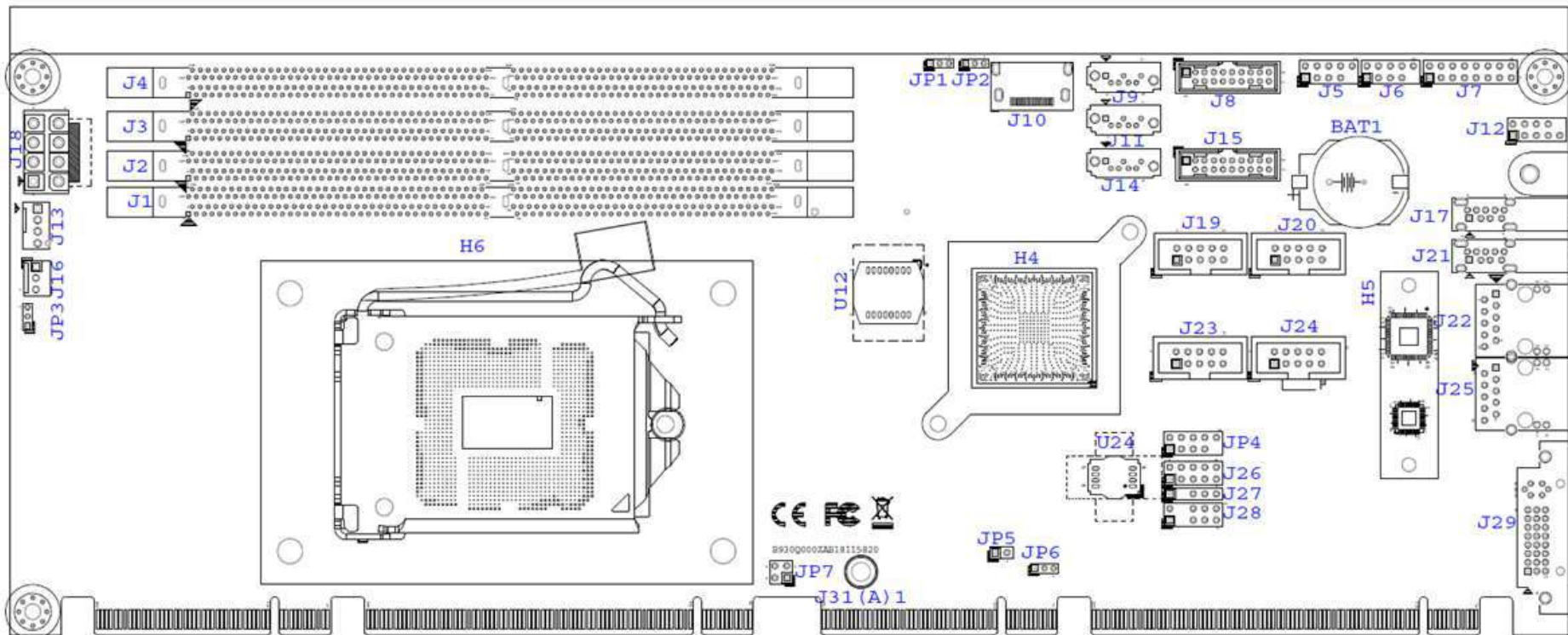

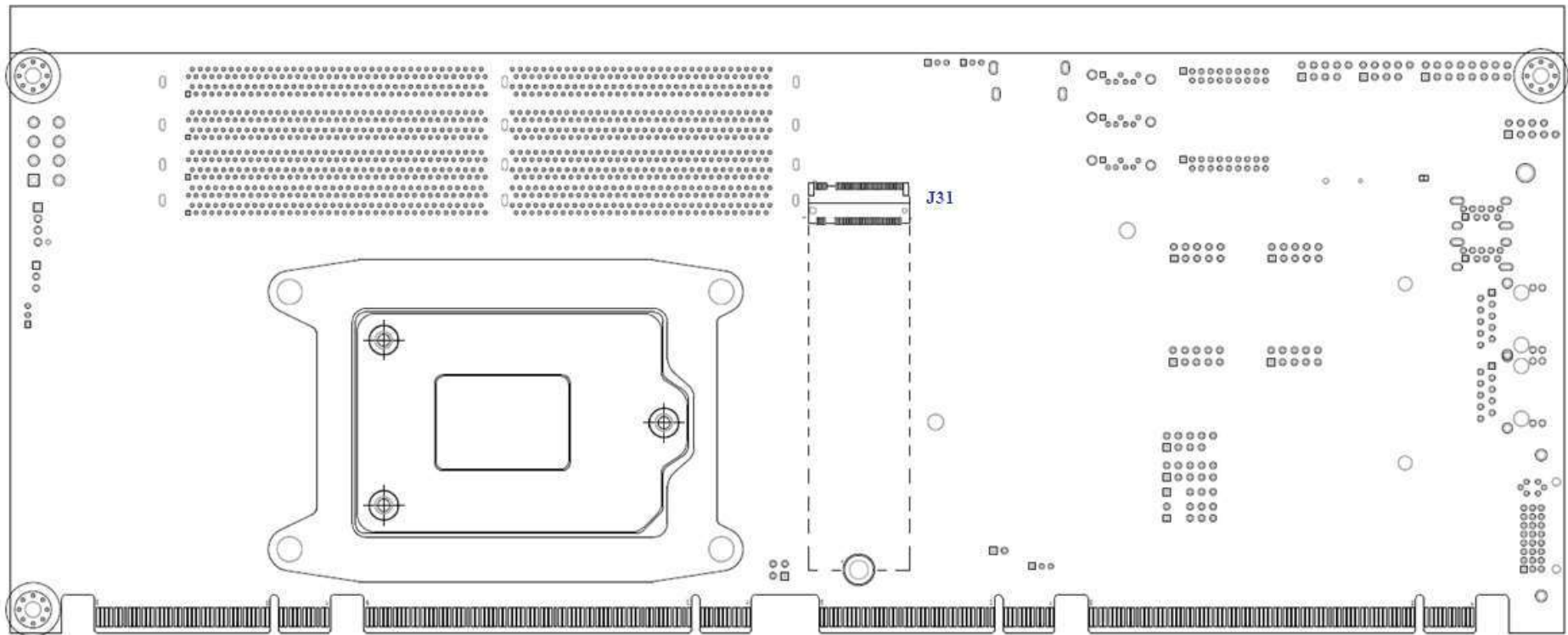

## 3.2 Jumpers Settings

For users to customize ROBO-8115VG2AR's features. In the following sections, Short means covering a jumper cap over jumper pins; Open or N/C (Not Connected) means removing a jumper cap from jumper pins. Users can refer to Figure 1 for the Jumper allocations.

### Jumper Table

The jumper settings are schematically depicted in this manual as follows:

#### Jump Function List:

Jumper	Function	Remark
JP1	Clear CMOS setting	Pitch 2.0mm
JP2	Reserve	
JP3	Reserve for IMVP8 PWM program	
JP4	LPC pin header	
JP6	ATX/AT Select Pin	Pitch 2.0mm
JP7	PCI-EX16 Configuration select	Pitch 2.54mm

## JP1: CMOS Setup(Pitch 2.0mm)



PIN No.	Description
1-2	★Normal
2-3	Clear CMOS

## JP6: AT/ATX Mode Selection(Pitch 2.0mm)

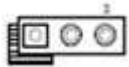

PIN No.	Description
1-2(Short)	AT Mode
2-3(Short)	★ATX Mode

## JP7: Configure PCIEX16,X8(Pitch 2.54mm): (Reserve)

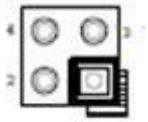

PIN No.		Description
1-2	3-4	Configuration
Short	Short	1x8,2x4
Open	Short	Reserve
Close	Open	2x8
Open	Open	★1x16

## 3.3 Connector Settings

Connector Allocation

I/O peripheral devices are connected to the interface connectors

### Connector Function List

Connector	Function	Remark
J1	DDR4 Long DIMM Channel A0.	
J2	DDR4 Long DIMM Channel A1	
J3	DDR4 Long DIMM Channel B0	
J4	DDR4 Long DIMM Channel B1	
J5	USB2.0 Connector	Pitch 2.54mm
J6	USB2.0 Connector.	Pitch 2.54mm
J7	Front panel Connector.	
J8	USB2.0/3.0 connector	
J9	SATA Connector.	
J10	HDMI Connector.	
J11	SATA Connector.	
J12	Audio Pin Header	
J13	CPU FAN Connector.	

## ROBO-8115VG2AR

J14	SATA Connector	
J15	USB2.0/3.0 connector.	
J16	System FAN Connector	
J17	USB2.0/3.0 connector(Type A).	
J18	ATX 8 Pin Connector(For CPU Power).	
J19	COM1 Pin Header.	
J20	COM2 Pin Header.	
J21	USB2.0/3.0 connector(Type A).	
J22	RJ45 Connector for I210.	
J23	COM4 Pin Header.	
J24	COM3 Pin Header.	
J25	RJ45 Connector for I219.	
J26	GPIO Pin Header.	
J27	SM Bus Pin Header.	
J28	PS2 KB/MS Pin Header.	
J29	DVI-I(DSUB).	
J31	M.2 Connector.	



## J5/J6: USB2.0 Connector(Pitch 2.54mm)

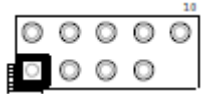

PIN No.	Description	PIN No.	Description
1	5V_DUAL	2	5V_DUAL
3	USB2A_DN	4	USB2B_DN
5	USB2A_DP	6	USB2B_DP
7	GND	8	GND
9	NC(Key)	10	NC

## J7: Front Panel Connector(Pitch 2.54mm)

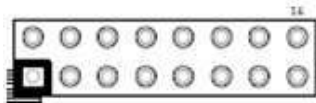

PIN No.	Description	PIN No.	Description
1	PWR_LED (+)	2	VCC
3	PWR_LED (-)	4	NC
5	I219_LAN (+)	6	NC
7	I219_LAN (-)	8	BUZZER
9	I210_LAN (-)	10	Ground
11	I210_LAN (+)	12	Power Button Signal
13	HDD_LED (+)	14	Reset Signal

15	HDD_LED (-)	16	Ground
----	-------------	----	--------

**J8/J15: USB2.0/3.0 connector(Pitch 2.0mm):**

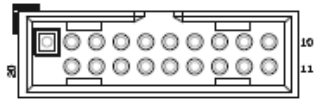

PIN No.	Description	PIN No.	Description
1	5V_Dual		
2	USB3.0_RX_N	19	5V_Dual
3	USB3.0_RX_P	18	USB3.0_RX_N
4	Ground	17	USB3.0_RX_P
5	USB3.0_TX_N	16	Ground
6	USB3.0_TX_P	15	USB3.0_TX_N
7	Ground	14	USB3.0_TX_P
8	USB2.0_N	13	Ground
9	USB2.0_P	12	USB2.0_N
10	Ground	11	USB2.0_P

## J9/J11/J14: SATA Connector

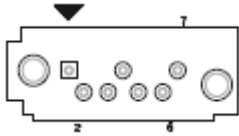

PIN No.	Description
1	Ground
2	TX_P
3	TX_N
4	Ground
5	RX_N
6	RX_P
7	Ground

**J10: HDMI Connector**



PIN No.	Description	PIN No.	Description
1	HDMI_D0_P	2	GND
3	HDMI_D0_N	4	HDMI_D1_P
5	GND	6	HDMI_D1_N
7	HDMI_D2_P	8	GND
9	HDMI_D2_N	10	HDMI_D3_P
11	GND	12	HDMI_D3_N
13	N/C	14	N/C
15	HDMI_DDC_CLK	16	HDMI_DDC_DATA
17	GND	18	5V_HDMI
19	HDMI_HPD		

**J12: Audio Pin Header(Pitch 2.54mm)**

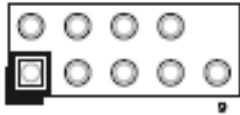

PIN No.	Description	PIN No.	Description
1	MIC_IN	2	Ground
3	LINE_IN_L	4	Ground
5	LINE_IN_R	6	Ground
7	AUDIO_OUT_L	8	Ground
9	AUDIO_OUT_R	10	Ground

**J13:CPU FAN Connector(Pitch 2.54mm)**



PIN No.	DESCRIPTION
1	GND
2	+12V
3	FAN_IN
4	FAN_OUT

## J16:SYSTEM FAN Connector(Pitch 2.54mm)

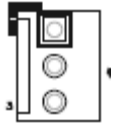

PIN No.	Description
1	GND
2	+12V
3	FAN_IN

## J17/J21: USB2.0/3.0 connector(Type A)

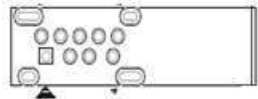

PIN No.	Description
1	5VDUAL
2	USB2_N
3	USB2_P
4	GND
5	USB_RX_N
6	USB_RX_P
7	GND
8	USB3_TX_N
9	USB3_TX_P

## J18: ATX 8 Pin Connector(For CPU Power)

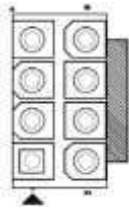

PIN No.	Description	PIN No.	Description
1	Ground	5	+12V
2	Ground	6	+12V
3	Ground	7	+12V
4	Ground	8	+12V

## J19/J20/J23/J24: COM1/COM2/COM3/COM4 Pin Header(Pitch 2.54mm)

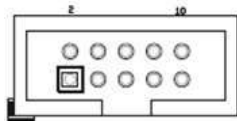

PIN No.	Description	PIN No.	Description
1	DCD#	2	RXD#
3	TXD#	4	DTR#
5	Ground	6	DSR#
7	RTS#	8	CTS#
9	RI#	10	NC

**Note:COM3/COM4 with BIOS set for RS232/RS422/RS485**

**J22/J25: LAN(RJ45)**

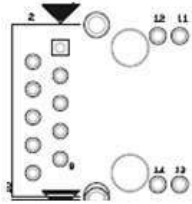

PIN No.	Description	PIN No.	Description
1	MDIO_P	2	MDIO_N
3	MDI1_P	4	MDI1_N
5	LAN_CT1	6	LAN_CT2
7	MDI2_P	8	MDI2_N
9	MDI3_P	10	MDI3_N
11	LED_100	12	LED_1000
13	LED_LINK#/ACT#	14	ACT_LED

**J26: GPIO Pin Header(Pitch 2.54mm)**



PIN No.	Description	PIN No.	Description
1	GPIO_0	2	GPIO_4
3	GPIO_1	4	GPIO_5
5	GPIO_2	6	GPIO_6
7	GPIO_3	8	GPIO_7
9	Ground	10	VCC



**J27: SM BUS Pin Header(Pitch 2.54mm)**

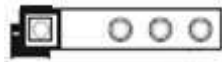

PIN No.	Description
1	SM_CLK
2	NC(Key)
3	GND
4	SM_DATA
5	+5V

**J28: PS2 KB/MS Pin Header(Pitch 2.54mm)**

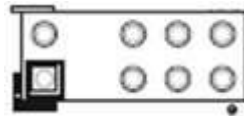

PIN No.	Description	PIN No.	Description
1	Mouse Data	2	Keyboard Data
3	NC	4	NC
5	Ground	6	Ground
7	5V_Dual	8	5V_Dual
9	Mouse Clock	10	Keyboard Clock

J29: DVI-I(D-SUB)



PIN No.	Description	PIN No.	Description
1	DVI_D2_N	16	DVI_HPDP
2	DVI_D2_P	17	DVI_D0_N
3	GND	18	DVI_D0_P
4	N/C	19	GND
5	N/C	20	N/C
6	DDC_CLK	21	N/C
7	DDC_DATA	22	GND
8	VSNC	23	DVI_CLK_P
9	DVI_D1_N	24	DVI_CLK_N
10	DVI_D1_P	C1	RED
11	GND	C2	GREEN
12	N/C	C3	BLUE
13	N/C	C4	HYSNC
14	DVI_VCC	C5	GND
15	GND	C6	GND

## J31: M.2 KEY-M slot

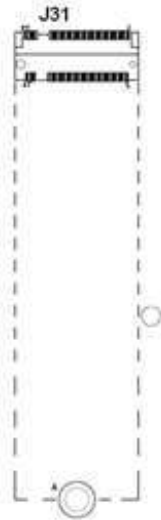

PIN No.	Description	PIN No.	Description
1	GND	2	3.3V
3	GND	4	3.3V
5	RX3_N	6	N/C
7	RX3_P	8	N/C
9	GND	10	LED#
11	TX3_N	12	3.3V
13	TX3_P	14	3.3V
15	GND	16	3.3V
17	RX2_N	18	3.3V
19	RX2_P	20	N/C
21	GND	22	N/C
23	TX2_N	24	N/C
25	TX2_P	26	N/C
27	GND	28	N/C
29	RX1_N	30	N/C
31	RX1_P	32	N/C
33	GND	34	N/C
35	TX1_N	36	N/C

37	TX1_P	38	DEVSLP
39	GND	40	N/C
41	RX0_N/SATA_B+	42	N/C
43	RX0_P/SATA_B-	44	N/C
45	GND	46	N/C
47	TX0_N/SATA_A-	48	N/C
49	TX0_P/SATA_A+	50	PERST#
51	GND	52	CLKREQ#
53	CLK_N	54	PEWAKE#
55	CLK_P	56	N/C
57	GND	58	N/C
59	KEY-M	60	KEY-M
61	KEY-M	62	KEY-M
63	KEY-M	64	KEY-M
65	KEY-M	66	KEY-M
67	N/C	68	SUSCLK
69	PEDET	70	3.3V
71	GND	72	3.3V
73	GND	74	3.3V
75	GND	76	

## 4 Signal Descriptions

### 4.1 Watch Dog Signal

```
#include <stdio.h>
#include <unistd.h>
#include <stdint.h>
#include <sys/io.h>

#define EC_IOSpace 0xE300 // EC IO Space Base Addr = 0xE000
                        // EC Internal Offset = 0x300
                        // EC IO Address = Base Addr + Internal offset

#define WDTCFG          0x06 // WDT Timer Control Register
                        // Bit 6: Write 1 to clear WDT pin event (COMe Only)
                        // Bit 4: 1: Driving WDT pin to Carrier (COMe Only)
                        //          0: System Reset
                        // Bit 1: 1: Min Mode
                        //          0: Second Mode
                        // Bit 0: 1: Enable WDT

#define WDTMIN          0x07 // WDT Timer Counter Register (Minute)
#define WDTSEC          0x08 // WDT Timer Counter Register (Second)
```

## ROBO-8115VG2AR

```
int Read_EC_SRAM(int offset)
{
    int Temp;
    Temp = inb_p(EC_IOSpace+offset);
    return Temp;
}

void Write_EC_SRAM(int offset, int value)
{
    outb_p(value,EC_IOSpace+offset);
}

//-----
// Reset WDT pin status
//-----
int WDT_Reset()
{
    int Temp;

    Temp = Read_EC_SRAM(WDTCFG);
    Write_EC_SRAM(WDTCFG,(Temp|0x40)); // Bit 6: Write 1 to clear WDT pin event
}
}
```

# ROBO-8115VG2AR

```
//-----  
// Main Function  
//-----  
int main (int argc, char ** argv)  
{  
    int Temp;  
  
    // Initial  
    if(iopl(3)!=0){  
        printf("error: I/O Permission Error!\n");  
        return 1;  
    }  
  
    // Enable WDT 10min, 20sec  
    Write_EC_SRAM(WDTSEC,5);           // 5 Sec  
    Write_EC_SRAM(WDTMIN,1);          // 1 min  
  
    // Enable WDT 5sec and WDT pin mode  
    Temp = Read_EC_SRAM(WDTCFG);  
    Write_EC_SRAM(WDTCFG,(Temp|0x13)); // Bit4: 1: Driving WDT pin  
                                        // BIT1: 1: Minute Mode  
                                        // Bit0: 1: Enable WDT
```

## ROBO-8115VG2AR

```
// Check Current WDT status
while((Read_EC_SRAM(WDTCFG)&0x01) != 0)
{
    printf("WDT Counting: %d M., %d S!\n",Read_EC_SRAM(WDTMIN),Read_EC_SRAM(WDTSEC));
}
}
```



## 4.2 GPIO Signal

```
#include <stdio.h>
#include <unistd.h>
#include <stdint.h>
#include <sys/io.h>

#define EC_IOSpace 0xE300 // EC IO Space Base Addr = 0xE000
                          // EC Internal Offset = 0x300
                          // EC IO Address = IO Space Base Addr + Internal offset

#define GPCR 0x2B // GPIO Control Register, Bit7 = GPO3, Bit6 = GPO2, ...,
                 //                               Bit3 = GPI3, Bit2 = GPI2, ...,
                 // 0: Output; 1: Input

#define GPDR 0x2C // GPIO Status Register, Bit7 = GPO3, Bit6 = GPO2, ...,
                 //                               Bit3 = GPI3, Bit2 = GPI2, ...,
                 // 0: Low; 1: High

int Read_EC_SRAM(int offset)
{
    int Temp;
    Temp = inb_p(EC_IOSpace+offset);
    return Temp;
}
```

## ROBO-8115VG2AR

```
void Write_EC_SRAM(int offset, int value)
{
    outb_p(value,EC_IOSpace+offset);
}

int main (int argc, char ** argv)
{
    int Temp;

    // Initial
    if(iopl(3)!=0){
        printf("error: I/O Permission Error!\n");
        return 1;
    }
    // Get GPI status
    Temp = Read_EC_SRAM(GPDR);                //Bit3-0: GPI3-0 status

    // Set GPO4 Output & High
    Temp = Read_EC_SRAM(GPDR);
    Write_EC_SRAM(GPDR,Temp|0x80);           //Bit7-4: Set GPO3-0 status, 0: Low 1: High

    return 0;
}
```

}

## 5 System Resources

### 5.1 Intel® Comet lake-S PCH

Intel® Q470E Chipset

Intel® W480E Chipset

### 5.2 Main Memory

ROBO-8115VG2AR provides 4 x 288-pin LONG-DIMM sockets which supports DDR4 ECC/non-ECC memory. The maximum memory can be up to 128GB. Memory clock and related settings can be detected by BIOS via SPD interface.

Watch out the contact and lock integrity of memory module with socket, it will impact on the system reliability. Follow normal procedures to install memory module into memory socket. Before locking, make sure that all modules have been fully inserted into the card slots.

## 5.3 Installing the Single Board Computer

To install your ROBO-8115VG2AR into standard chassis or proprietary environment, please perform the following:

Step 1 : Check all jumpers setting on proper position

Step 2 : Install and configure CPU,CPU cooling and memory module on right position

Step 3 : Place ROBO-8115VG2AR into the dedicated position in the system

Step 4 : Attach cables to existing peripheral devices and secure it

### **WARNING**

Please ensure that mother board is properly inserted and fixed by mechanism.

### **Note:**

Please refer to section 6.3.1 to 6.3.4 to install INF/Graphic/LAN

#### 5.3.1 Chipset Component Driver

ROBO-8115VG2AR is based on Intel® Q470E/W480E chipset and desktop/workstation processors including Xeon W series /Core™i9 / i7 / i5 / i3 sku . It's a new chipset that some old operating systems might not be able to recognize. To overcome this compatibility issue, for Windows Operating Systems such as Windows 8, please install its INF before any of other Drivers are installed. You can find very easily this chipset component driver in ROBO-8115VG2AR CD-title

# ROBO-8115VG2AR

## 5.3.2 Intel® HD Graphics 630

ROBO-8115VG2AR has integrated Intel® HD Graphics 630 which supports DirectX 12 · OpenCL 2.0 · OpenGL 4.5. It is the most advanced design to gain an outstanding graphic performance. ROBO-8115VG2AR supports VGA+DVI-D by DVI-I connector on bracket, and on board HDMI display output. This combination makes ROBO-8115VG2AR an excellent performance hardware.

### **Drivers Support**

Please find the Graphic driver in the ROBO-8115VG2AR CD-title. The driver supports Windows 10.

## 5.3.3 Intel LAN I210AT/I219LM Gigabit Ethernet Controller

- Intel I210AT Gigabit Ethernet controller and 1x RJ45 connectors on bracket
- Intel I219LM Gigabit Ethernet controller and 1x RJ45 connectors on bracket

### **Drivers Support**

Please find Intel I210AT/I219LM LAN driver in /Ethernet directory of ROBO-8115VG2AR CD-title. The driver supports Windows 10.

PCI Express Base Specification, Revision 2.0 <https://www.pcisig.com/specifications>

## 6 BIOS Setup Items

### 6.1 Introduction

The following section describes the BIOS setup program. The BIOS setup program can be used to view and change the BIOS settings for the module. Only experienced users should change the default BIOS settings.

### 6.2 BIOS Setup

Power on the computer and the system will start POST (Power on Self Test) process. When the message below appears on the screen, press <Delete> or <ESC> key will enter BIOS setup screen.

#### **Press <ESC > or <Delete> to enter SETUP**

If the message disappears before responding and still wish to enter Setup, please restart the system by turning it OFF and On or pressing the RESET button. It can be also restarted by pressing <Ctrl>, <Alt>, and <Delete> keys on keyboard simultaneously.

#### **Press <F1> to Run General Help or Resume**

The BIOS setup program provides a General Help screen. The menu can be easily called up from any menu by pressing <F1>. The Help screen lists all the possible keys to use and the selections for the highlighted item. Press <Esc> to exit the Help Screen.

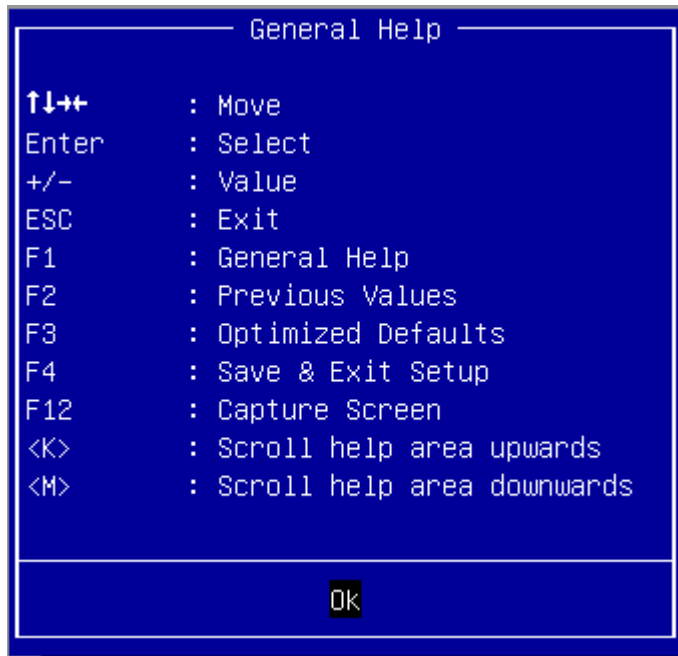



# ROBO-8115VG2AR

## 6.2.1 Main

Use this menu for basic system configurations, such as time, date etc.

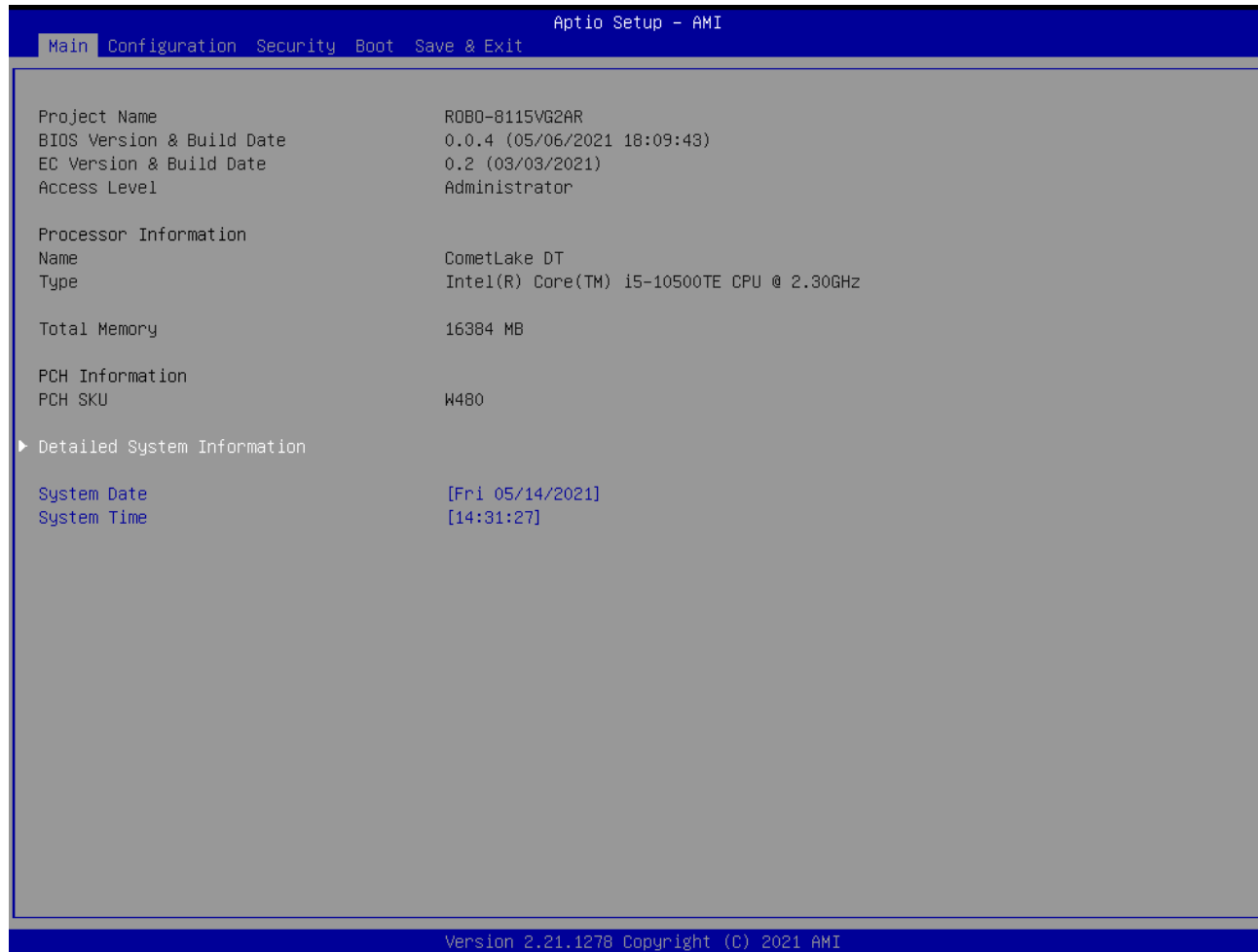

# ROBO-8115VG2AR

The screenshot displays the 'Main' menu of the Aptio Setup - AMI BIOS. The 'Detailed System Information' section is expanded, showing the following details:

Section	Item	Value	
FSP Information	FSP version	09.03.38.20	
	RC version	09.00.38.20	
	Build Date		
	FSP Mode	Dispatch Mode	
Board Information	Board ID	ROBO-8115VG2AR	
	Fab ID	Default string	
	LAN PHY Revision	A6 (B2 Stepping)	
Processor Information	Name	CometLake DT	
	Type	Intel(R) Core(TM) i5-10500TE CPU @ 2.30GHz	
	Speed	2300 MHz	
	ID	0xA0650	
	Stepping	G0	
	Package	LGA1200	
	Number of Processors	6Core(s) / 12Thread(s)	
	Microcode Revision	BE	
	GT Info	GT2 (0x9BC8)	
	eDRAM Size	N/A	
	IGFX VBIOS Version	IGFX VBIOS Version	N/A
		IGFX GOP Version	9.0.1109
Memory RC Version		0.0.0.74	
Total Memory		16384 MB	
Memory Frequency		2400 MHz	
Channel 0 Slot 0		Populated & Enabled	
Channel 0 Slot 1		Not Populated / Disabled	
Channel 1 Slot 0	Not Populated / Disabled		

Version 2.21.1278 Copyright (C) 2021 AMI

# ROBO-8115VG2AR

```

IGFX VBIOS Version      N/A
IGFX GOP Version       9.0.1109
Memory RC Version      0.0.0.74
Total Memory           16384 MB
Memory Frequency       2400 MHz
Channel 0 Slot 0      Populated & Enabled
    Size              16384 MB (DDR4)
Channel 0 Slot 1      Not Populated / Disabled
Channel 1 Slot 0      Not Populated / Disabled
Channel 1 Slot 1      Not Populated / Disabled

PCH Information
Name                  CML PCH-H
PCH SKU              W480
Stepping             A0
ChipsetInit Base Revision 26
ChipsetInit OEM Revision 0
Package              Not Implemented Yet
TXT Capability of Platform/PCH Supported
Production Type      Production

Dual Output Fast Read support Not supported
Read ID/Status Clock Freq 48 MHz
Write and Erase Clock Freq 48 MHz
Fast Read Clock Freq 48 MHz
Fast Read support      Supported
Read Clock Freq       30 MHz
Number of Components  1 Component
SPI Component 0 Density 32 MB

eSPI Flash Sharing Mode G3
ME FW Version         14.0.37.1165
    
```

Version 2.21.1278 Copyright (C) 2021 AMI

Feature	Description	Options
<b>Detail system information</b>	Detail system information	
<b>System Date</b>	The date format is <Day>, <Month> <Date> <Year>. Use [ + ] or [ - ] to configure system Date.	
<b>System Time</b>	The time format is <Hour> <Minute> <Second>. Use [ + ] or [ - ] to configure system Time.	

# ROBO-8115VG2AR

## 6.2.2 Configuration

Use this menu to set up the items of special enhanced features

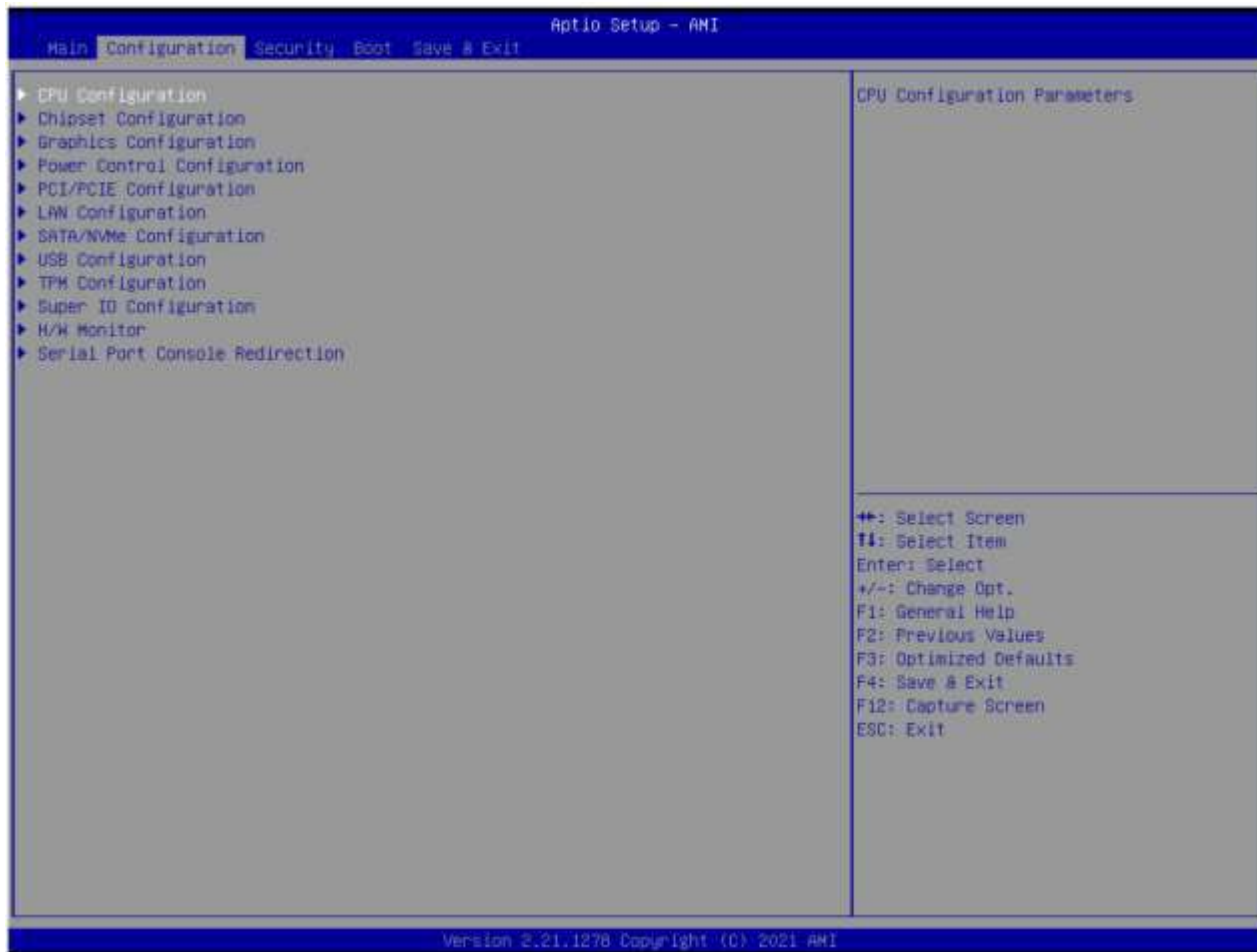

# ROBO-8115VG2AR

## CPU Configuration

### CPU Configuration Parameters

The screenshot displays the BIOS configuration interface for the ROBO-8115VG2AR. The title bar reads "Aptio Setup - AMI" and the current screen is "Configuration". The "CPU Configuration" section is active, showing various processor settings. A legend on the right side of the screen explains the navigation keys.

Parameter	Value
Type	Genuine Intel(R) CPU 0000 @ 3.00GHz
ID	0xA0650
Speed	3000 MHz
L1 Data Cache	32 KB x 6
L1 Instruction Cache	32 KB x 6
L2 Cache	256 KB x 6
L3 Cache	12 MB
L4 Cache	N/A
VMX	Supported
SMX/TXT	Supported
Active Processor Cores	[All]
Hyper-Threading	[Enabled]
Boot performance mode	[Max Non-Turbo Performance]
Intel (VMX) Virtualization Technology	[Enabled]
Intel(R) SpeedStep(tm)	[Enabled]
Intel(R) Speed Shift Technology	[Enabled]
Turbo Mode	[Enabled]
C states	[Enabled]
Enhanced C-states	[Enabled]
C-State Auto Demotion	[C1 and C3]
C-State Un-demotion	[C1 and C3]
Package C-State Demotion	[Disabled]
Package C-State Un-demotion	[Disabled]
CState Pre-Wake	[Enabled]
IO MWAIT Redirection	[Disabled]
Package C State Limit	[Auto]

Number of cores to enable in each processor package.

Navigation Legend:

- ←: Select Screen
- : Select Item
- Enter: Select
- +/-: Change Opt.
- F1: General Help
- F2: Previous Values
- F3: Optimized Defaults
- F4: Save & Exit
- F12: Capture Screen
- ESC: Exit

Version 2.21.1278 Copyright (C) 2021 AMI

# ROBO-8115VG2AR

Feature	Description	Options
<b>Active Processor Cores</b>	Number of cores to enable in each processor package.	★All, 1, 2, 3,4,5
<b>Hyper-Threading</b>	Enable or Disable Hyper-Threading Technology	Disabled, ★Enabled
<b>Boot performance mode</b>	Select the performance state that the BIOS will set starting from reset vector	Max Battery ★Max Non-Turbo Performance Turbo Performance
<b>Intel (VMX) Virtualization Technology</b>	When enabled, a VMM can utilize the additional hardware capabilities provided by Vander pool Technology.	Disabled, ★Enabled
<b>Intel® Speed Step™</b>	Allows more than two frequency ranges to be supported.	Disabled, ★Enabled
<b>Intel® Speed Shift Technology</b>	Enable/Disable Intel® Speed Shift Technology support. Enabling will expose the CPPC v2 interface to allow for hardware controlled P-states	Disabled, ★Enabled
<b>Turbo Mode</b>	Enable/Disable processor Turbo Mode (requires Intel Speed Step or Intel Speed Shift to be available and enabled)	Disabled, ★Enabled
<b>C states</b>	Enable/disable CPU Power Management. Allows CPU to go to C states when it's not 100% utilized	Disabled, ★Enabled
<b>Enhanced C-states</b>	Enable/Disable C1E. When enabled, CPU will switch to minimum speed when all cores enter C-state	Disabled, ★Enabled
<b>C-State Auto Demotion</b>	Configure C-State Auto Demotion	Disable, C1, C3 ★C1 and C3
<b>C-State Un-demotion</b>	Configure C-State Un-demotion	Disable, C1, C3 ★C1 and C3
<b>Package C State Demotion</b>	Package C-State Demotion	★Disabled, Enabled
<b>Package C State Un-demotion</b>	Package C-State Un-demotion	★Disabled, Enabled
<b>CState Pre-Wake</b>	Disable – Sets bit 30 of POWER_CTL MSR(0x1FC) to 1 to disable the Cstate Pre-Wake	Disabled, ★Enabled
<b>IO MWAIT Redirection</b>	When set, will map IO_read instructions sent to IO registers PMG_IO_BASE_ADDRBASE+offset to MWAIT(offset)	★Disabled, Enabled
<b>Package C State Limit</b>	Maximum Package C State Limit Setting. Cpu Default: Leaves to Factory default value. Auto: Initializes to deepest available Package C States Limit	C0/C1,C2,C3,C6,C7,C7S,C8,C9,C10,Cpu Default, ★Auto

# ROBO-8115VG2AR

## Chipset Configuration Configuration Chipset feature

The screenshot displays the 'Aptio Setup - AMI' BIOS interface. At the top, a blue bar contains the text 'Configuration'. Below this, the 'Chipset Configuration' section is visible, listing several settings with their current states in brackets:

- VT-d [Enabled]
- Above 4GB MMIO BIOS assignment [Disabled]
- HD Audio [Enabled]
- Port 80h Redirection [LPC Bus]
- Me FW Image Re-Flash [Disabled]
- AMT Configuration (expanded) [Enabled]
- ECC Support [Enabled]

To the right of the configuration list, the text 'VT-d capability' is present. Below the configuration list, a legend of keyboard shortcuts is provided:

- ⇐: Select Screen
- ↑: Select Item
- Enter: Select
- +/-: Change Opt.
- F1: General Help
- F2: Previous Values
- F3: Optimized Defaults
- F4: Save & Exit
- F12: Capture Screen
- ESC: Exit

At the bottom of the screen, a blue bar contains the text 'Version 2.21.1278 Copyright (C) 2021 AMI'.

## ROBO-8115VG2AR

Feature	Description	Options
<b>VT-d</b>	VT-d Capability	Disabled, ★Enabled
<b>Above 4GB MMIO BIOS assignment</b>	Enable/Disable above 4GB MemoryMappedIO BIOS assignment This is enabled automatically when Aperture Size is set to 2048MB	★Disabled, Enabled
<b>HD Audio</b>	Control Detection of the HD-Audio device	Disabled, ★Enabled
<b>Port 80h Redirection</b>	Control where the Port 80h cycles are sent	★LPC Bus, PCIE Bus
<b>Me FW Image Re-Flash</b>	Enable/Disable Me FW Image Re-Flash function.	★Disabled, Enabled
<b>ECC Support</b>	Enable/disable DDR ECC Support	Disabled, ★Enabled



# ROBO-8115VG2AR

## AMT Configuration

Configure Intel® Active Management Technology Parameters

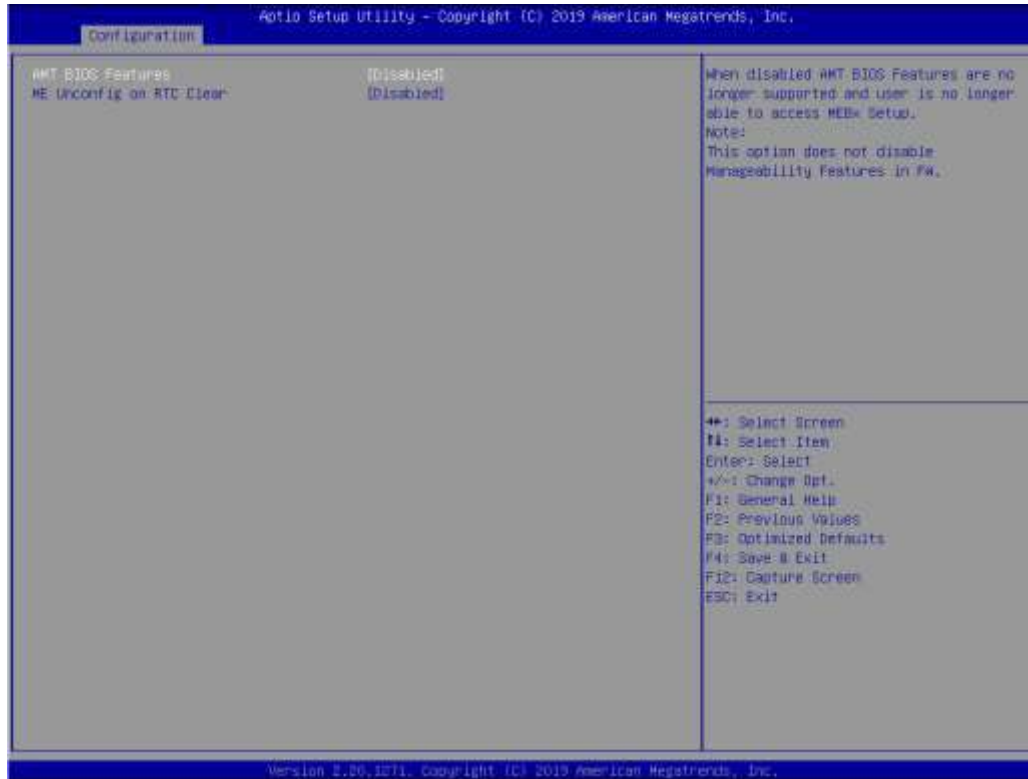

Feature	Description	Options
<b>AMT BIOS Features</b>	When disable AMT BIOS Features are no longer supported and user is no longer able to access MEBx Setup. Note: This option does not disable Manageability Features in FW	★ Disabled, Enabled
<b>ME Unconfig on RTC Clear</b>	When Disable ME will not be unconfigured on RTC Clear	★ Disabled, Enabled

# ROBO-8115VG2AR

## Graphics Configuration

### Configuration Graphics Settings

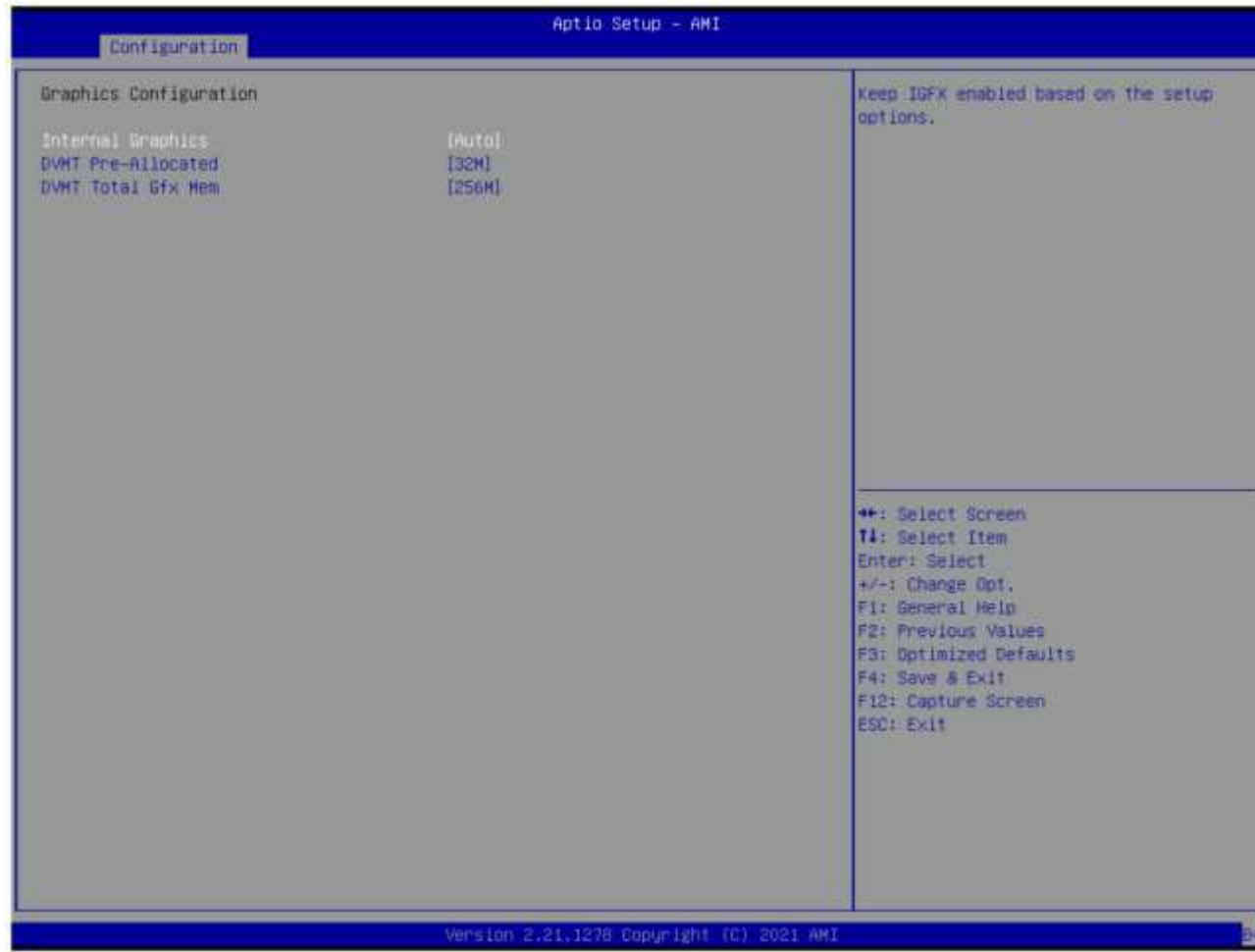

# ROBO-8115VG2AR

Feature	Description	Options
<b>Internal Graphics</b>	Keep IGFX enable based on the setup options.	★Auto, Disable, Enable
<b>DVMT Pre-Allocated</b>	Select DVMT 5.0 Pre-Allocated (Fixed) Graphics Memory size used by the Internal Graphics Device.	0M, ★32M,64M,4M,8M,12M,16M,20M,24M,28M,32M/F7,36M,40M,44M,48M,52M,56M,60M
<b>DVMT Total Gfx Mem</b>	Select DVMT5.0 Total Graphic Memory size used by the Internal Graphics Device	★256M, 128M, MAX

## Power Control Configuration

### System Power Control Configuration Parameters



Feature	Description	Options
<b>Enable Hibernation</b>	Enables or Disables System ability to Hibernate (OS/S4 Sleep State). This option may be not effective with some OS.	★Enabled , Disabled
<b>ACPI Sleep State</b>	Select the highest ACPI sleep state the system will enter when the SUSPEND button is pressed.	★S3 (Suspend to RAM), Suspend Disabled
<b>Restore AC Power Loss</b>	Specify what state to go to when power is re-applied after a power failure (G3 state)	★Power Off, Power On, Last State
<b>Wake System from S5</b>	Enable or disable System wake on alarm event. When enabled, System will wake on the hr::min::sec Specified/programmed by the Tools from OS	★Disabled, Enabled

# ROBO-8115VG2AR

## PCI/PCIE Configuration

PCI, PCI-X and PCI Express Settings



Feature	Description	Options
PEG Port Lane Width	Set PEG port Lane width	★1x16, 2x8,1x8. 2x4

# ROBO-8115VG2AR

## PEG Port Configuration

The screenshot displays the 'Aptio Setup - AMI' BIOS configuration interface. The 'Configuration' tab is selected. The main area is titled 'PEG Port Configuration' and lists settings for three PEG ports: PEG 0:1:0 (x16 Gen3), PEG 0:1:1 (Not Present), and PEG 0:1:2 (Not Present). For each port, the 'Enable Root Port' is set to [Auto], and 'Max Link Speed' and 'Max Link Width' are also set to [Auto]. A secondary panel on the right is titled 'Enable or Disable the Root Port'. At the bottom of the screen, a legend lists navigation keys: ++ for Select Screen, **T** for Select Item, Enter for Select, +/- for Change Opt., F1 for General Help, F2 for Previous Values, F3 for Optimized Defaults, F4 for Save & Exit, F12 for Capture Screen, and ESC for Exit. The footer indicates 'Version 2.21.1278 Copyright (C) 2021 AMI'.

Port	Configuration
PEG 0:1:0	x16 Gen3
Enable Root Port	[Auto]
Max Link Speed	[Auto]
Max Link Width	[Auto]
PEG 0:1:1	Not Present
Enable Root Port	[Auto]
Max Link Speed	[Auto]
Max Link Width	[Auto]
PEG 0:1:2	Not Present
Enable Root Port	[Auto]
Max Link Speed	[Auto]
Max Link Width	[Auto]

Legend:

- ++: Select Screen
- T**: Select Item
- Enter: Select
- +/-: Change Opt.
- F1: General Help
- F2: Previous Values
- F3: Optimized Defaults
- F4: Save & Exit
- F12: Capture Screen
- ESC: Exit

# ROBO-8115VG2AR

Feature	Description	Options
Enable Root Port	Enable or Disable the Root Port	★AUTO, Disable, Enable
Max Link Speed	Configure PEG 0:1:0 / 0:1:1 / 0:1:2 Max Speed	★AUTO, Gen1, Gen2, Gen3
Max Link Width	Force PEG link to retrain to x1/2/4/8	★AUTO, Force x1, Force x2, Force x4, Force x8,



# ROBO-8115VG2AR

## PCIE RP #1(To BackPlane) / #6(Onboard I210) / #7(Onboard PCIe-2-PCI) / #21(Onboard M.2)



# ROBO-8115VG2AR

Feature	Description	Options
<b>PCIE RP #1(To BackPlane) #6(Onboard I210) #7(Onboard PCIe-2-PCI) #21(Onboard M.2)</b>	Control the PCI Express Root Port.	★Enabled , Disabled
<b>ASPM 1/6/7/21</b>	Set the ASPM Level: Force L0s – Force all links to L0s State AUTO-BIOS auto configure DISABLE – Disables ASPM	★Disabled, L0s, L1, L0sL1, Auto
<b>PCIe Speed</b>	Select PCI Express port speed	★Auto, Gen1, Gen2, Gen3

# ROBO-8115VG2AR

## LAN Configuration

Configuration onboard LAN device.

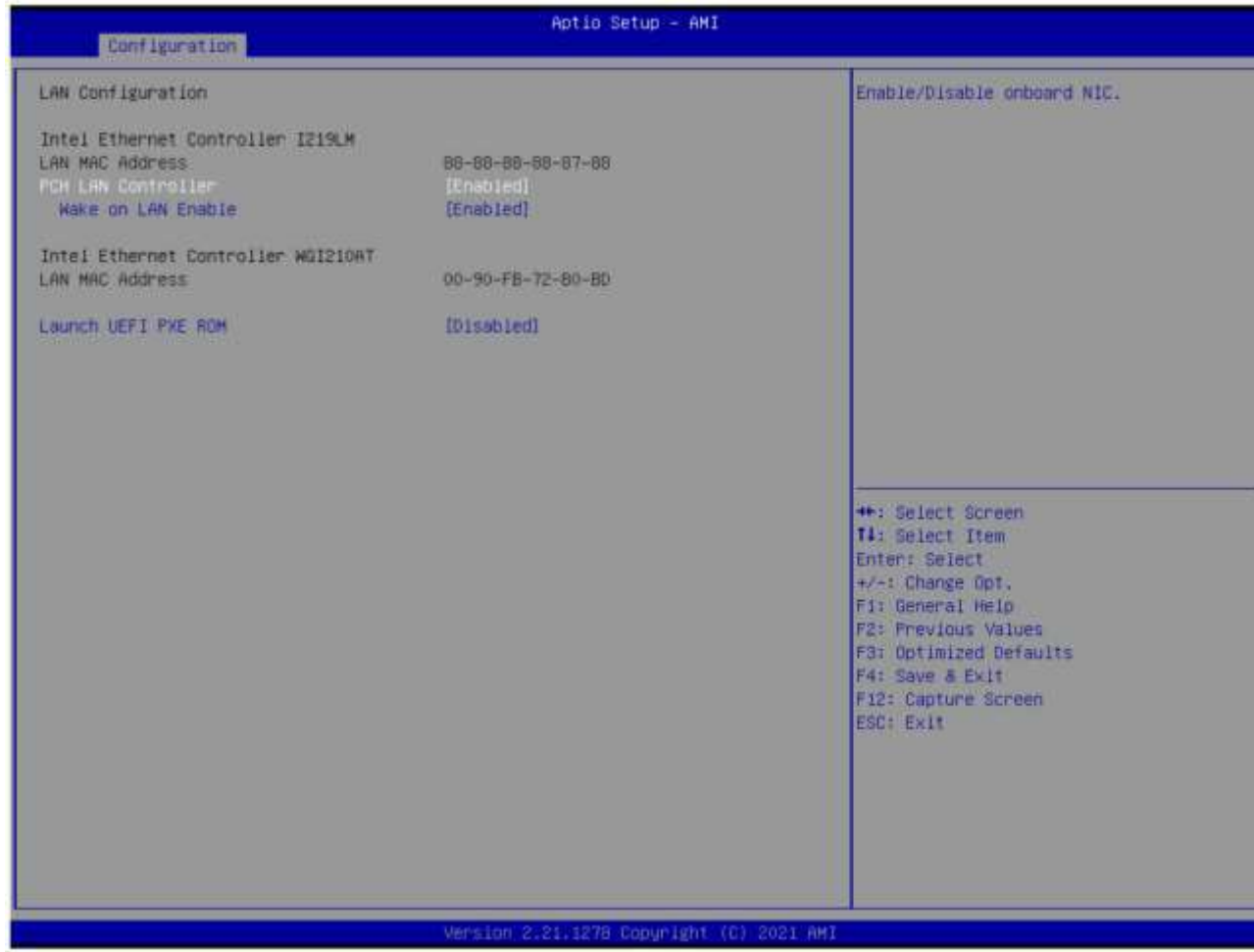

## ROBO-8115VG2AR

Feature	Description	Options
<b>PCH LAN Controller</b>	Enable or disable onboard NIC	★Enabled , Disabled
<b>Wake on LAN</b>	Enable or disable integrated LAN to wake the system.	★Enabled , Disabled
<b>Launch UEFI PXE Rom</b>	Enable/Disable UEFI Network Stack	★Disabled, Enabled
<b>Ipv4 PXE Support</b>	If disable, IPv4 PXE boot support will not be available.	Disabled, ★Enabled
<b>Ipv4 HTTP Support</b>	If disable, IPv4 HTTP boot support will not be available.	Disabled, ★Enabled
<b>Ipv6 PXE Support</b>	If disable, IPv6 PXE boot support will not be available.	Disabled, ★Enabled
<b>Ipv6 HTTP Support</b>	If disable, IPv6 HTTP boot support will not be available.	Disabled, ★Enabled
<b>PXE boot wait time</b>	Wait time in seconds to press ESC key to abort the PXE boot	★0
<b>Media detect count</b>	Number of times the presence of media will be checked	★1

# ROBO-8115VG2AR

## SATA / NVMe Configuration

### SATA / NVMe Device Options Settings



# ROBO-8115VG2AR

```
Configuration
SATA And RST Configuration
SATA Controller(s) [Enabled]
SATA Mode Selection [AHCI]
SATA Controller Speed [Default]

Serial ATA Port 0 (OnBoard J9) Empty
Software Preserve Unknown
Port 0 [Enabled]
Hot Plug [Disabled]
Configured as eSATA Hot Plug supported
SATA Device Type [Hard Disk Drive]
Serial ATA Port 1 (OnBoard J11) Empty
Software Preserve Unknown
Port 1 [Enabled]
Hot Plug [Disabled]
Configured as eSATA Hot Plug supported
SATA Device Type [Hard Disk Drive]
Serial ATA Port 2 (OnBoard J14) Empty
Software Preserve Unknown
Port 2 [Enabled]
Hot Plug [Disabled]
Configured as eSATA Hot Plug supported
SATA Device Type [Hard Disk Drive]
Serial ATA Port 3 (BackPlane) Empty
Software Preserve Unknown
Port 3 [Enabled]
Hot Plug [Disabled]
Configured as eSATA Hot Plug supported
SATA Device Type [Hard Disk Drive]
Serial ATA Port 4 (BackPlane) Empty
Software Preserve Unknown
Port 4 [Enabled]
Hot Plug [Disabled]
Configured as eSATA Hot Plug supported
SATA Device Type [Hard Disk Drive]
Serial ATA Port 5 (OnBoard M.2) Empty
Software Preserve Unknown
Port 5 [Enabled]
Hot Plug [Disabled]
Configured as eSATA Hot Plug supported
SATA Device Type [Hard Disk Drive]
```

# ROBO-8115VG2AR



# ROBO-8115VG2AR

Feature	Description	Options
<b>SATA Controller(s)</b>	Enable/disable SATA Device.	★Enabled , Disabled
<b>SATA Mode Selection</b>	Determines how SATA controller(s) operate.	★AHCI, Intel RST Premium with Intel Optane System Acceleration
<b>SATA Controller Speed</b>	Indicates the maximum speed the SATA controller can support	★Default, Gen1, Gen2, Gen3
<b>Serial ATA Port</b> Port 0: onboard J9 Port 1: onboard J11 Port 2: onboard J14 Port 3: backplane Port 4: backplane Port 5: onboard M.2		
<b>Port 0~5</b>	Enable or Disable SATA Port	Disabled, ★Enabled
<b>Hot Plug</b>	Designates this port as Hot Pluggable	★Disabled, Enabled
<b>SATA Device Type</b>	Identify the SATA port is connected to Solid State Drive or Hard Disk Drive	★Hard Disk Drive, Solid State Drive



# ROBO-8115VG2AR

## USB Configuration

### USB Configuration Parameters

The screenshot shows the 'Aptio Setup - AMI' BIOS interface. The 'Configuration' tab is selected. The 'USB Configuration' section displays the following settings:

- USB Configuration: Enables Legacy USB support. AUTO option disables legacy support if no USB devices are connected. DISABLE option will keep USB devices available only for EFI applications.
- USB Controllers: 1 XHCI
- USB Devices: 1 Keyboard
- Legacy USB Support: [Enabled]
- XHCI Hand-off: [Enabled]
- USB Mass Storage Driver Support: [Enabled]

Navigation instructions are listed at the bottom right of the screen:

- ↑↓: Select Screen
- ←→: Select Item
- Enter: Select
- +/-: Change Opt.
- F1: General Help
- F2: Previous Values
- F3: Optimized Defaults
- F4: Save & Exit
- F12: Capture Screen
- ESC: Exit

At the bottom left, the 'USB Mass Storage Driver Support' setting is shown as [Enabled]. The footer of the BIOS screen reads 'Version 2.21.127B Copyright (C) 2021 AMI'.

## ROBO-8115VG2AR

Feature	Description	Options
<b>Legacy USB Support</b>	Enables Legacy USB support. AUTO option disables legacy support if no USB devices are connected. DISABLE option will keep USB devices available only for EFI application	★Enabled , Disabled, Auto
<b>XHCI Hand-off</b>	This is a workaround for Oses without XHCI hand-off support. The XHCI ownership change should be claimed by XHCI driver	★Enabled , Disabled
<b>USB Mass Storage Driver Support</b>	Enable/Disable USB Mass Storage Driver Support	★Enabled , Disabled

# ROBO-8115VG2AR

## TPM Configuration

### Trusted Computing Setting

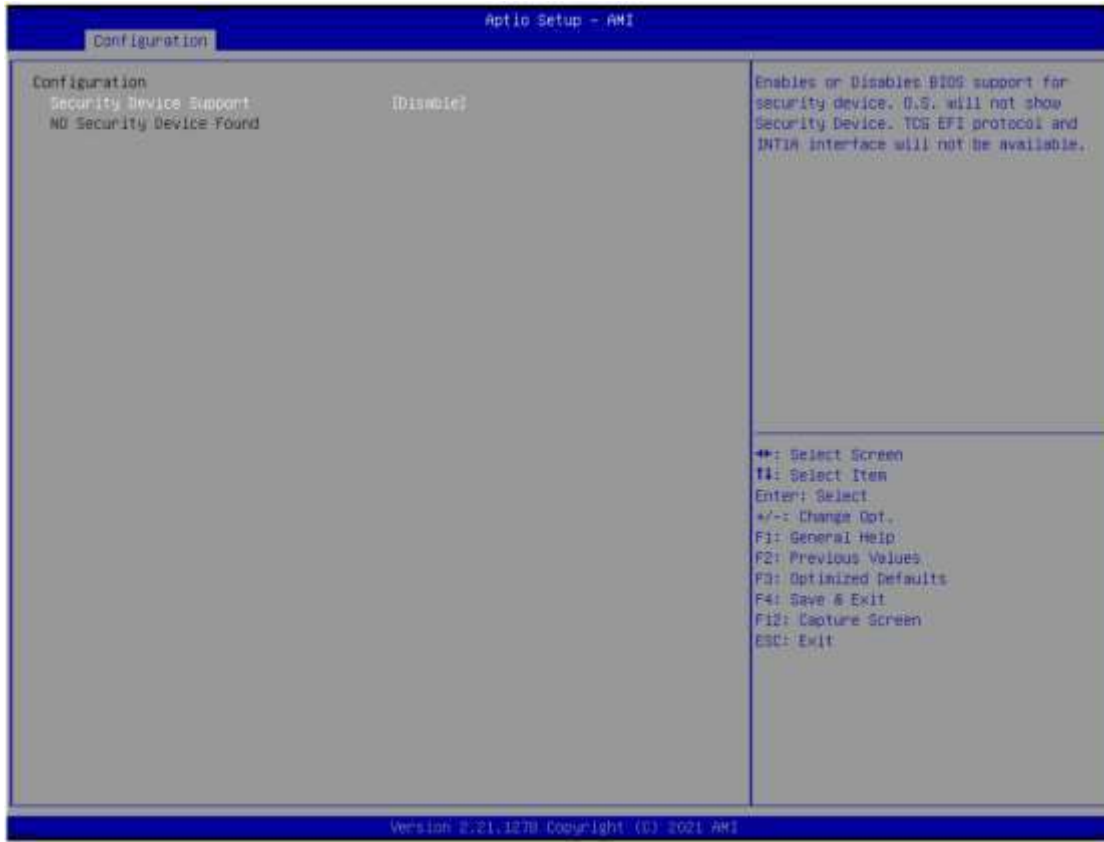

Feature	Description	Options
<b>Security Device Support</b>	Enables or Disables BIOS support for security device. O.S. will not show Security Device. TCG EFI protocol and INT1A Interface will not be available.	★ Disabled, Enabled

# ROBO-8115VG2AR

## Super IO Configuration

System Super IO Chip Parameters.

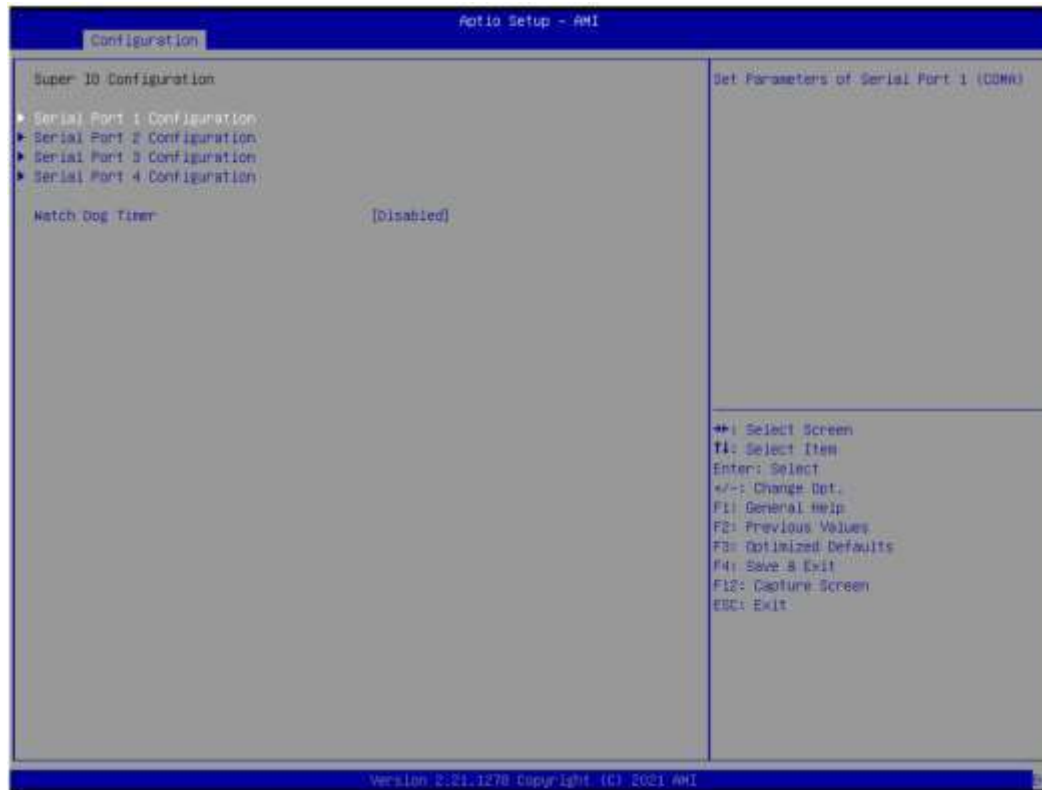

Feature	Description	Options
Watch Dog Timer	Enable/Disable Watch Dog Timer	★ Disabled, Enabled
Timer Unit	Select Timer count unit of WDT	★ Second, Minute
Timer value	Set WDT Timer value	★ 20

# ROBO-8115VG2AR

## Serial Port 1 Configuration Set Parameters of Serial Port 1



Feature	Description	Options
<b>Serial Port</b>	Enable or Disable Serial Port (COM)	★Enabled, Disabled
<b>Change Settings</b>	Select an optimal settings for Super IO Device	★IO=3F8h; IRQ=4, Auto, IO=240h; IRQ=3,4,5,6,7,10,11,12 IO=248h; IRQ=3,4,5,6,7,10,11,12 IO=250h; IRQ=3,4,5,6,7,10,11,12 IO=258h; IRQ=3,4,5,6,7,10,11,12

# ROBO-8115VG2AR

## Serial Port 2 Configuration Set Parameters of Serial Port 2



Feature	Description	Options
<b>Serial Port</b>	Enable or Disable Serial Port (COM)	★Enabled, Disabled
<b>Change Settings</b>	Select an optimal settings for Super IO Device	★IO=2F8h; IRQ=3, Auto, IO=240h; IRQ=3,4,5,6,7,10,11,12 IO=248h; IRQ=3,4,5,6,7,10,11,12 IO=250h; IRQ=3,4,5,6,7,10,11,12 IO=258h; IRQ=3,4,5,6,7,10,11,12

# ROBO-8115VG2AR

## Serial Port 3 Configuration Set Parameters of Serial Port 3



# ROBO-8115VG2AR

Feature	Description	Options
<b>Serial Port</b>	Enable or Disable Serial Port (COM)	★Enabled, Disabled
<b>RS-232/422/485 Control Option</b>	Serial port 3 RS-232/422/485 Control Option	★RS-232, RS 485 HALF DUPLEX, RS-422 FULL DUPLEX
<b>RS-485 Auto Flow Control</b>	Enable/Disable RS-485 Auto Flow Function	★Disabled, Enabled
<b>Change Settings</b>	Select an optimal settings for Super IO Device	★IO=3E8h; IRQ=11, Auto, IO=240h; IRQ=3,4,5,6,7,10,11,12 IO=248h; IRQ=3,4,5,6,7,10,11,12 IO=250h; IRQ=3,4,5,6,7,10,11,12 IO=258h; IRQ=3,4,5,6,7,10,11,12



# ROBO-8115VG2AR

## Serial Port 4 Configuration Set Parameters of Serial Port 4



# ROBO-8115VG2AR

Feature	Description	Options
<b>Serial Port</b>	Enable or Disable Serial Port (COM)	★Enabled, Disabled
<b>RS-232/422/485 Control Option</b>	Serial port 3 RS-232/422/485 Control Option	★RS-232, RS 485 HALF DUPLEX, RS-422 FULL DUPLEX
<b>RS-485 Auto Flow Control</b>	Enable/Disable RS-485 Auto Flow Function	★Disabled, Enabled
<b>Change Settings</b>	Select an optimal settings for Super IO Device	★IO=2E8h; IRQ=10, Auto, IO=240h; IRQ=3,4,5,6,7,10,11,12 IO=248h; IRQ=3,4,5,6,7,10,11,12 IO=250h; IRQ=3,4,5,6,7,10,11,12 IO=258h; IRQ=3,4,5,6,7,10,11,12

# ROBO-8115VG2AR

## H/W Monitor

Monitor hardware status

The screenshot displays the 'Aptio Setup - AMI' interface, specifically the 'Configuration' tab. The screen is divided into two main sections. The left section lists various hardware monitoring parameters and their current values. The right section contains a description for the 'Smart Fan' settings and a list of navigation keys.

Parameter	Value
Smart Fan1 Function	[Disabled]
Smart Fan2 Function	[Disabled]
CPU temperature	: +65 °C
System temperature	: 0 °C
Fan1 Speed	: 4739 RPM
Fan2 Speed	: N/A
Vcore	: +0.921 V
+3.3V	: +3.360 V
+5V	: +5.049 V
+12V	: +12.137 V
VDIMM	: +1.182 V

Disable / Enable the Smart Fan Control.

←→: Select Screen  
↑↓: Select Item  
Enter: Select  
+/-: Change Opt.  
F1: General Help  
F2: Previous Values  
F3: Optimized Defaults  
F4: Save & Exit  
F12: Capture Screen  
ESC: Exit

Version 2.21.1276 Copyright (C) 2021 AMI

# ROBO-8115VG2AR

Feature	Description	Options
<b>Smart Fan1/2 Function</b>	Enable or Disable Smart Fan Control	★ Disabled, Enabled
<b>Smart Fan1/2 Control Mode</b>	Smart Fan Mode Select	★ Thermal Cruise™ Mode, Fan Speed Cruise™ Mode Smart Fan™ III Mode Fan Control Mode
<b>Fan1/2 Tolerance Temp</b>	In Thermal Cruise Mode\ Smart Fan III Mode: Tolerance of Target Temperature. In Fan Speed Cruise Mode: Tolerance of Target Speed.	★ 5
<b>Fan1/2 Start Target Temp</b>	In Thermal Cruise Mode: Start Temperature. In Fan Speed Cruise Mode: High Byte of Target Speed. In Smart Fan III Mode: Target Temperature. In Fan Control Mode: Fan Speed (0-100%)	★ 40
<b>Fan1/2 Full Target Temp</b>	In Thermal Cruise Mode: Full speed Temperature. In Fan Speed Cruise Mode: Low Byte of Target Speed.	★ 60
<b>Fan1/2 Low End</b>	In Thermal Cruise Mode\ Smart Fan III Mode: Low End of Fan Speed (0-100%)	★ 5

# ROBO-8115VG2AR

## Serial Port Console Redirection

### Serial Port Console Redirection



Feature	Description	Options
Console Redirection	Console Redirection Enable or Disable	★Disabled, Enabled

# ROBO-8115VG2AR

## Console Redirection Settings

The screenshot shows the 'Aptio Setup - AMI' interface with the 'Configuration' tab selected. The 'Console Redirection Settings' section is expanded, displaying the following configuration:

Setting	Value
Terminal Type	[ANSI]
Bits per second	[115200]
Data Bits	[8]
Parity	[None]
Stop Bits	[1]
Flow Control	[None]
VT-UTF8 Combo Key Support	[Enabled]
Recorder Mode	[Disabled]
Resolution 100x31	[Disabled]
Putty KeyPad	[VT100]

Emulation: ANSI: Extended ASCII char set. VT100: ASCII char set. VT100+: Extends VT100 to support color, function keys, etc. VT-UTF8: Uses UTF8 encoding to map Unicode chars onto 1 or more bytes.

++: Select Screen  
↑↓: Select Item  
Enter: Select  
+/-: Change Opt.  
F1: General Help  
F2: Previous Values  
F3: Optimized Defaults  
F4: Save & Exit  
F12: Capture Screen  
ESC: Exit

Version 2.21.1278 Copyright (C) 2021 AMI

# ROBO-8115VG2AR

Feature	Description	Options
<b>Terminal Type</b>	Emulation: ANSI: Extended ASCII char set. VT100: ASCII char set. VT100+: Extends VT100 to support color, function keys, etc. VT-UTF8: Uses UTF8 encoding to map Unicode chars onto 1 or more bytes.	★ANSI, VT100, VT100+, VT-UTF8
<b>Bits per second</b>	Select Serial port transmission speed. The speed must be matched on other side. Long or noisy lines may require lower speeds.	★115200, 9600, 19200, 38400, 57600
<b>Data bits</b>	Data bits	★8, 7
<b>Parity</b>	A parity bit can be sent with the data bits to detect some transmission errors. Even: parity bit is 0 if the num of 1's in the data bits is even. Odd: parity bit is 0 if num of 1's in the data bits is odd. Mark: parity bit is always 1. Space parity bit is always 0. Mark and Space Parity do not allow for error detection. They can be used as an additional data bit.	★None, Even, Odd, Mark, Space
<b>Stop Bits</b>	Stop bits indicate the end of a serial data packet. (A start bit indicates the beginning). The standard setting is 1 stop bit. Communication with slow devices may require more than 1 stop bit.	★1,2
<b>Flow Control</b>	Flow control can prevent data loss from buffer overflow. When sending data, if the receiving buffers are full, a 'stop' signal can be sent to stop the data flow. Once the buffers are empty, a 'start' signal can be sent to re-start the flow. Hardware flow control uses two wires to send start/stop signal.	★None, Hardware RTS/CTS
<b>VT-UTF8 Combo Key Support</b>	Enable VT-UTF8 Combination Key Support for ANSI/VT100 terminals	★Enabled, Disabled
<b>Recorder Mode</b>	With this mode enabled only text will be sent. This is to capture Terminal data.	★Disabled, Enabled
<b>Resolution 100x31</b>	Enables or disables extended terminal resolution	★Disabled, Enabled
<b>Putty KeyPad</b>	Select FunctionKey and KeyPad on Putty	★VT100, LINUX,XTERMR6, SCO,ESCN,VT400

## 6.2.3 Security



Feature	Description	Options
<b>Password Check Mode</b>	[Setup] check password when enter setup screen. [Power on] check password on every time system power on.	★ Setup, Power on
<b>Administrator Password</b>	Set Administrator Password	



# ROBO-8115VG2AR

## 6.2.4 Boot



## ROBO-8115VG2AR

Feature	Description	Options
Setup Prompt Timeout	Number of seconds to wait for setup activation key. 65535(0xFFFF) means indefinite waiting.	★1
Bootup NumLock State	Select the keyboard NumLock state	★On, Off
Full Screen LOGO	Enables or disables Quiet Boot option and Full screen Logo.	★Disabled, Enabled
Boot mode select	Select boot mode LEGACY/UEFI	★UEFI, Legacy
Boot Option #1~6	Sets the system boot order	★UEFI, Legacy
UEFI Application Boot Priorities	Specifies the Boot Device Priority sequence from available UEFI Application	

# ROBO-8115VG2AR

## 6.2.5 Save & Exit

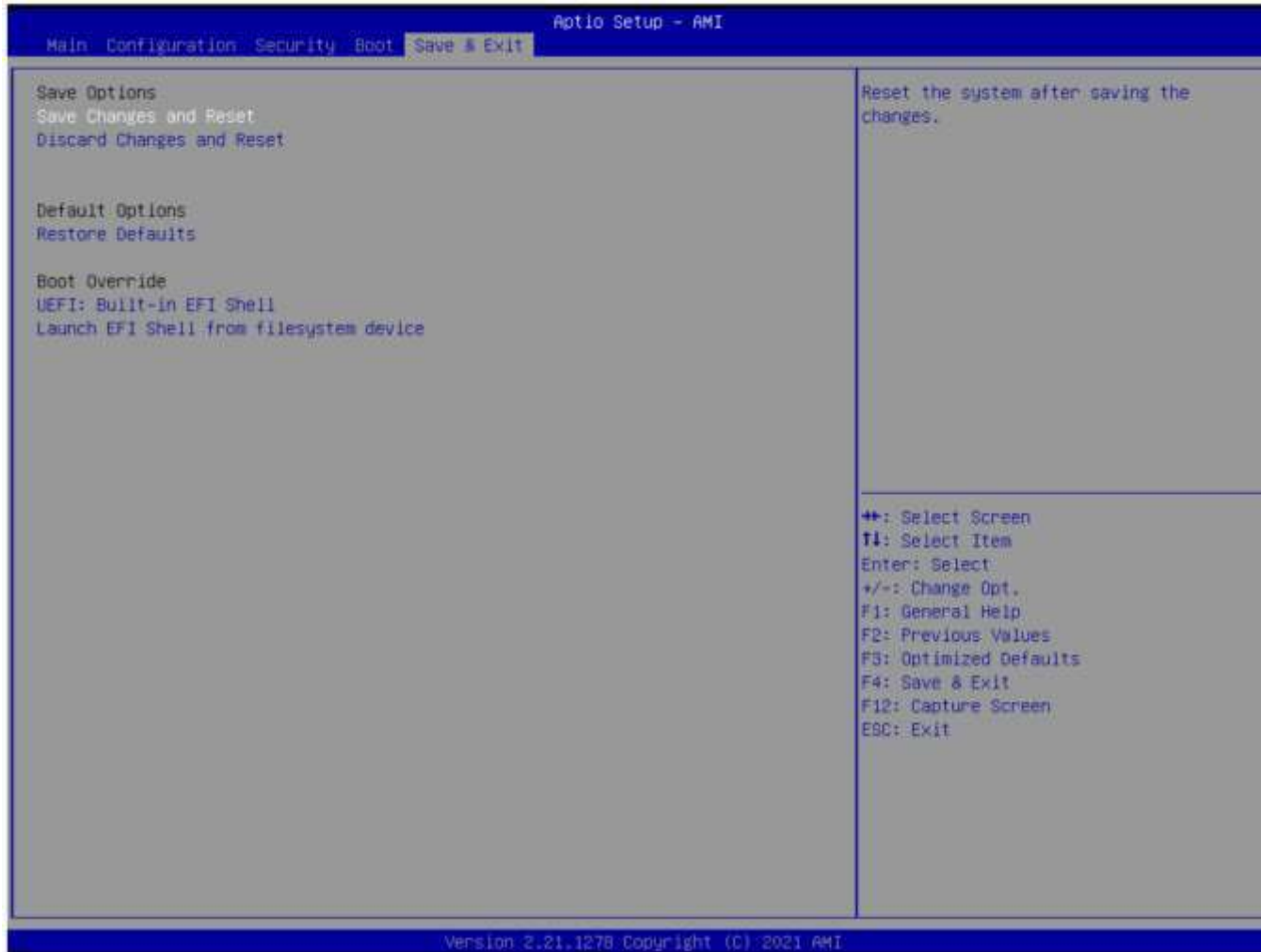

## ROBO-8115VG2AR

Feature	Description	Options
<b>Save Changes and Reset</b>	Reset the system after saving the changes.	
<b>Discard Changes and Reset</b>	Reset system setup without saving any changes.	
<b>Restore Defaults</b>	Restore/Load Default values for all the setup options.	
<b>UEFI: Built-in EFI Shell</b>	Reset the system after saving the changes. (Boot option filter: UEFI only)	
<b>Launch EFI Shell from filesystem device</b>	Attempts to Launch EFI Shell application (Shell.efi) from one of the available filesystem devices.	

## 7 Troubleshooting

This section provides a few useful tips to quickly get ROBO-8115 running with success. This section will primarily focus on system integration issues, in terms of BIOS setting, and OS diagnostics.

### 7.1 Hardware Quick Installation

#### ATX Power Setting

Unlike other Single board computer, ROBO-8115 supports ATX PSU only. Therefore, there is no other setting that needs to be set up. However, there are only two connectors that must be connected— J18 (ATX 8 Pin Connector (For CPU Power)) on the ROBO-8115 board & 20+4 pins ATX Power Connector on the backplane.

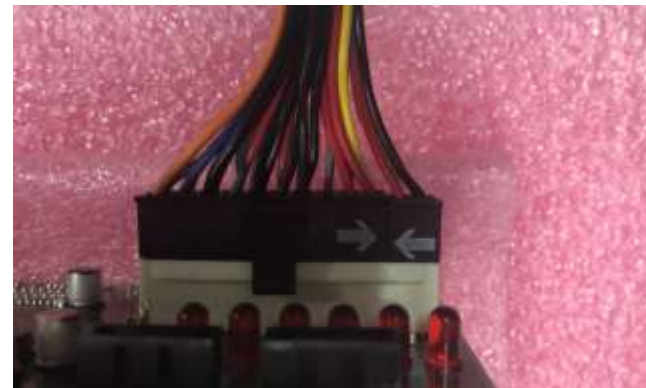

# ROBO-8115VG2AR

## Serial ATA

Unlike IDE bus, each Serial ATA channel can only connect to one SATA hard disk at a time;

The installation of Serial ATA is simpler and easier than IDE, because SATA hard disk doesn't require setting up Master and Slave, which can reduce mistake of hardware installation.

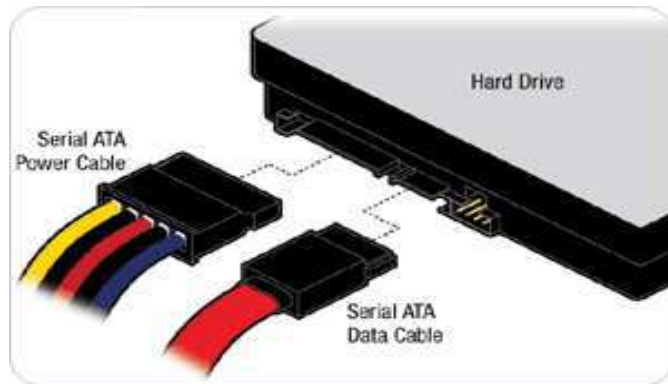

ROBO-8115 can support four SATA interface (SATAIII, 6.0Gb/s) on board. It has SATA ports on board.

## 7.2 BIOS Setting

It is assumed that users have correctly adopted modules and connected all the devices cables required before turning on ATX power. DDR4 long DIMM Memory, keyboard, mouse, SATA hard disk, VGA connector, power cable of the device, ATX accessories are good examples that deserve attention. With no assurance of properly and correctly accommodating these modules and devices, it is very possible to encounter system failures that result in malfunction of any device.

To make sure that you have a successful start with ROBO-8115, it is recommended, when going with the boot-up sequence, to hit "delete" or "ESC" key and enter the BIOS setup menu to tune up a stable BIOS configuration so that you can wake up your system far well.

## Loading the default optimal setting

When prompted with the main setup menu, please scroll down to “Restore Defaults”, press “Enter” and select “Yes” to load default optimal BIOS setup. This will force your BIOS setting back to the initial factory configurations. It is recommended to do this so you can be sure the system is running with the BIOS setting that Portwell has highly endorsed. As a matter of fact, users can load the default BIOS setting at any time when system appears to be unstable in boot up sequence.

## 7.3 FAQ

### Information & Support

**Question:** I forgot my password of system BIOS, what am I supposed to do?

**Answer:** You can switch off your power supply then find the JP1 on the ROBO-8115 board to set it from 1-2 short to 2-3 short and wait 5 seconds to clean your password then set it back to 1-2 short to switch on your power supply.

### JP1: CMOS Setup(Pitch 2.0mm)



PIN No.	Description
1-2	★Normal
2-3	Clear CMOS

## ROBO-8115VG2AR

**Question:** How to update the BIOS file of ROBO-8115

**Answer:**

1. Please visit web site of [Portwell download center](https://www.portwell.com.tw/support-center/download-center/) as below hyperlink

<https://www.portwell.com.tw/support-center/download-center/>

2. Select “[Search download](#)” and type the keyword “[ROBO-8115](#)”.

3. Find the “[BIOS](#)” page and download the ROM file and flash utility.

4. Unzip file to bootable USB flash drive which can boot to dos mode. Then execute the “update.bat” or “update.efi”. It will start to update BIOS. NOTE: Once you use “update.efi” to update BIOS, it must be get into the SHELL MODE to update BIOS

5. When you see the “[FPT Operation Passed](#)” message, which means the BIOS update processes finished. Please cut the AC power off and **wait for 10 seconds** before powering on.

6. When you see the “[Programming success](#)” message, which means the BIOS update processes finished. Please cut the AC power off and **wait for 10 seconds** before powering on.

**Question: What are the display options while using ROBO-8115 board?**

**Answer:** - The ROBO-8115 supports DVI-I and HDMI display output.

Note:

Please visit our Download Center to get the Catalog, User manual, BIOS, and driver files.

<https://www.portwell.com.tw/support-center/download-center/>

If you have other additional technical information or request which is not covered in this manual, please fill in the technical request form as below hyperlink.

<https://www.portwell.com.tw/support-center/technical-request/?lang=zh-hant>

We will do our best to provide a suggestion or solution for you.

Thanks



## 8 Portwell Software Service

1. If you have customized requirements of BIOS, you can contact person of our company or branch.
2. If you have requirements of WDT、GPIO APP, you can contact our headquarter or branch, and we can render you assistance on developing.

Portwell Worldwide:	
<a href="#">Portwell, Inc.</a>	E-mail: <a href="mailto:info@portwell.com.tw">info@portwell.com.tw</a>
<a href="#">Shanghai Portwell</a>	E-mail: <a href="mailto:info@portwell.com.cn">info@portwell.com.cn</a>
<a href="#">Portwell Japan, Inc</a>	E-mail: <a href="mailto:info@portwell.co.jp">info@portwell.co.jp</a>
<a href="#">American Portwell Technology</a>	E-mail: <a href="mailto:info@portwell.com">info@portwell.com</a>
<a href="#">European Portwell Technology</a>	E-mail: <a href="mailto:info@portwell.eu">info@portwell.eu</a>
<a href="#">Portwell UK Ltd.</a>	E-mail: <a href="mailto:info@portwell.co.uk">info@portwell.co.uk</a>
<a href="#">Portwell Deutschland GmbH</a>	E-mail: <a href="mailto:info@portwell.eu">info@portwell.eu</a>
<a href="#">Portwell India Technology</a>	E-mail: <a href="mailto:info@portwell.in">info@portwell.in</a>
<a href="#">Portwell Korea, Inc.</a>	E-mail: <a href="mailto:info@portwell.co.kr">info@portwell.co.kr</a>
<a href="#">Portwell Latin America</a>	E-mail: <a href="mailto:vendas@portwell.com.br">vendas@portwell.com.br</a>

## 9 Industry Specifications

### 9.1 Industry Specifications

The list below provides links to industry specifications that apply to Portwell modules.

Low Pin Count Interface Specification, Revision 1.0 (LPC) <http://www.intel.com/design/chipsets/industry/lpc.htm>

Universal Serial Bus (USB) Specification, Revision 2.0 <http://www.usb.org/home>

PCI Specification, Revision 2.3 <https://www.pcisig.com/specifications>

Serial ATA Specification, Revision 3.0 <http://www.serialata.org/>

PCI Express Base Specification, Revision 2.0 <https://www.pcisig.com/specifications>